

electro-harmonix

User Reference Manual



95000

performance loop laboratory

TABLE OF CONTENTS

MEET THE 95000... 3

What's in the Box? | Main Features | Specifications

QUICK START GUIDE... 4

RECORDING AND WORKING WITH MULTITRACK LOOPS | Make Connections and Set Input Level | Prior to Recording | Record a Multitrack Loop | Overdub onto a Track | Undo and Redo | Erase a Track | Erase a Loop | Record 2 Tracks Simultaneously (Stereo) | Record a Quantized Loop | **MIXING** | Prepare to Mix | Perform a Mix | **RESTORE FACTORY SETTINGS**

BASIC TERMINOLOGY AND KEY CONCEPTS... 7

MONITORING... 9

DRY OUTPUT L/R Faders and Pan Knobs | CLIX LVL Knob | HEADPHONE LVL Knob | MASTER LVL Knob

THE RECORD TRANSPORT... 10

INPUT LEVEL L/ R Knobs and CLIP LEDs | NEW LOOP Button | TRACK Footswitch | UNDO Footswitch | RECORD Footswitch | PLAY (◻ ▶) Footswitch | LOOP ▽△ Selection Footswitches | PUNCH Button | OCT Button | REVERSE Button | EXT. CLOCK Button | QUANTIZE Button

TRACKS, TRACK SELECTION, MIXDOWN, TEMPO... 14

TRACKS OVERVIEW | TRACK Faders | TRACK SELECT Buttons | MIXDOWN Track | TRACK PAN Knobs | MIXDOWN Fader | MIXDOWN Button | TEMPO Slider | TAP Button | CLIX LEDs

LED DISPLAY AND CONTROL... 17

LED DISPLAY | VALUE Push to Jump Knob | PAGE Button | **PRIMARY MODE PAGES** | LOOP/DUB Mode | BARS/BEATS Mode | MIDI CH/SYNC Mode | SYNC Modes | **SECONDARY MODE PAGES** | CLIX Metronome | TEMPO Slider Resolution | Count-In | Loop Fade-Out

REAR CONNECTIONS AND CONTROLS... 20

9VDC 400mA Power Jack | microSDHC Card Slot | USB Connector | MIDI OUT Connector | MIDI IN Connector | EXPRESSION PEDAL Jack | HEADPHONE Jack | MONITOR OUT Jack | L and R OUTPUT Jacks | AUX IN Jack | +48V Phantom Power Button | L and R INPUT Combo Jacks

IN DEPTH: RECORDING TRACKS... 22

Prepare to Record a New Loop | Non-Quantize vs. Quantize Loop Recording | Stereo Mode | Record a New Loop | End a New Loop | Loop Length and Storage Capacity | Change Loop Numbers | Erase Loops and Tracks

IN DEPTH: OVERDUBBING TRACKS... 25

Choose a Track to Overdub | Overdubbing | DUB Settings (aka Feedback) | Manipulating Sounds While Overdubbing | Punching-In

IN DEPTH: MIXDOWN... 27

Mixdown Basics | Performing a Mixdown | After the Mixdown | Constant Tempo Mixdown Mode | Using Constant Tempo Mixdown Mode

MEMORY CARD AND USB... 29

About the microSDHC Memory Card | Overview of microSDHC Memory Card Requirements, Size and Performance | How to Format microSDHC Memory Cards | How to Remove the microSDHC Card | USB Port: How to Interface the 95000 with a Computer | 95000's microSDHC Card File System | Backing-Up Files | Restoring Files | Importing Audio Files

MIDI SYNC... 32

IN (Internal Clock Sync Mode) | XT (Normal External Clock Mode) | BX (Beat Sync External Clock Mode) | TUTORIAL: the 95000 as MIDI Clock Slave and MIDI Clock Master

MIDI CONTROLLER AND PROGRAM MESSAGES... 35

Overview | Set the MIDI Channel | MIDI Control Change (CC) Messages | MIDI Program Change (PC) Messages | MIDI Thru | Change Loop Numbers with MIDI | MIDI CC Tables | MIDI Program Change (PC) Messages

SIGNAL PATH DIAGRAM... 38

FACTORY DRUM LOOPS... 39

WARRANTY... 40

FCC COMPLIANCE... 40

©2017 Electro-Harmonix. All rights reserved. 95000 and Electro-Harmonix and logo are trademarks of New Sensor/Electro-Harmonix. Product and company names used within the manual are trademarks of their respective companies.

95000 Manual Version 1.0

MEET THE 95000

Thank you for purchasing the Electro-Harmonix 95000 Performance Loop Laboratory. Please set aside some time to read this manual and familiarize yourself with this unique instrument's layout and operation. Then keep the manual close by to use as a reference guide.

The manual is divided into the following basic sections:

- What's in the Box, Main Features, Specifications
- Quick Start Guide
- Basic Terminology and Key Concepts
- Overview of the controls of the 95000
- In-depth look at the operation of the 95000
- MIDI functions and assignments

What's in the Box

- 95000 Performance Loop Laboratory
- User Reference Manual
- 16GB microSDHC Memory Card
- 9.6VDC 0.5A power supply

Main Features

- Total recording time up to 375 minutes with 16GB card
- Stores up to 100 multi-track loops per card
- 6 tracks plus one stereo Mixdown track
- Records one or two tracks (stereo or 2 mono) at once
- Stereo dry output level controls
- Undo/Redo your last recording/overdub per track
- Overdub (DUB) with adjustable feedback amount
- Reverse button instantly changes loop direction
- Octave button instantly halves the loop's playback speed
- Quantize function allows for playing along with CLIX metronome and locking loops to external devices
- Combo Mic/Instrument/Line input with adjustable gain and phantom power
- Headphone output
- Data entry rotary knob
- 4-digit LED display
- TAP Tempo
- Octave/Reverse/Quantize functions
- Removable microSDHC Memory Card (16GB card included)
- USB port for easy transfer of files to and from computer
- MIDI Clock sync and control
- Expression pedal input jack to control loop audio volume
- 20 Factory-supplied drum loops
- Convenient dedicated footswitch functions
- Rugged, all-metal stage-worthy chassis

Specifications

- Current Draw: 400mA at 9V. Maximum allowable power supply voltage: 10.5 VDC
- Digital Audio Specifications: 16-bit/44.1 kHz
- microSDHC Memory Card Size: 4GB-32GB
- Maximum Loop Recording Time on Included 16GB microSDHC Memory Card: up to 375 minutes
- Headphones Output Power: 0.1W into 16 ohms
- 9.6VDC 0.5A power supply
- Input Impedances:
 - L and R 1/4" Inputs: 2M Ω
 - L and R XLR Inputs: 2.5k Ω
 - AUX Input: 9.5k Ω
- Output Impedances:
 - L and R 1/4" Outputs: 400 Ω
 - Monitor 1/4" Output: 400 Ω
 - Headphones Output: 2 Ω

QUICK START GUIDE



RECORDING AND WORKING WITH MULTITRACK LOOPS

Make Connections and Set Input Level

1. Plug your instrument or microphone into either the L or R INPUT jacks and adjust the corresponding INPUT knob so that the CLIP LED barely lights up on your loudest notes.
2. Connect the MONITOR OUT jack to an amplifier or mixer. Turn up the HEADPHONE LVL knob to approximately 50%.
3. Plug the supplied AC Adapter into an AC outlet and insert its output plug into the power jack on the rear panel of the 95000.

Prior to Recording

1. Raise the corresponding L or R DRY OUTPUT fader so that you can hear your instrument.
2. Raise the TRACK 1 fader so that you can hear your recording when you finish.
3. Make sure the QUANTIZE LED is off.
4. If you do not want to hear the metronome, turn the CLIX LVL knob down to zero; if you do want to hear the metronome, adjust to taste. Adjust the tempo of the metronome with the TEMPO slider or by pressing the TAP button—in time—at least twice.
5. Set the TEMPO slider to 50% (or your preferred tempo if listening to the metronome). You may also tap in the tempo using the TAP button.
6. Find an empty loop by pressing the LOOP UP (Δ) or DOWN (∇) footswitches. The left two digits of the display show you the loop number. If there is a dot next to the loop number then the loop contains audio; no dot indicates that the loop is empty.

Record a Multitrack Loop

1. Press the RECORD footswitch to start recording immediately. The 95000 will begin recording onto TRACK 1. The red 4-digit LED displays the progression of the loop in bars and beats.
2. When you are ready to end the loop and set the loop length, press either the RECORD or PLAY ($\square \triangleright$) footswitches. Press RECORD to stop recording and immediately begin playback of the loop you just recorded. Press PLAY to loop the 95000 back to the beginning, put the 95000 into OVERDUB mode, and automatically continue recording onto TRACK 2. To exit OVERDUB mode, press the RECORD button.
3. To record on another track, press the TRACK footswitch to cycle through the 6 tracks OR go directly to a track by pressing its illuminated button. The lit track button indicates the track is enabled for recording.

Overdub onto a Track

1. You can continuously overdub onto any one (or pair) of the tracks.
2. Record a New Loop onto TRACK 1. See **Record a Multitrack Loop** (above).
3. Press the TRACK footswitch until TRACK 1 is lit, or you may directly press the TRACK 1 button.
4. Press the RECORD button. Both the RECORD and PLAY LEDs will light up to show that you are in Overdub mode. The lit TRACK 1 LED indicates you are overdubbing onto TRACK 1.
5. Move TRACK 1's fader to adjust its volume.
6. Repeat these steps to overdub onto any track number—just press the TRACK footswitch until the track on which you want to overdub is selected.

Undo and Redo

1. Select the track you want to undo.
2. Press and release the UNDO footswitch. The last layer of audio on the track is removed and the previous version of the track begins playing. The UNDO LED lights up.
3. If only one layer of audio was recorded on the track, then the track plays back silence.
4. Press and release the UNDO footswitch to return—or redo—the audio layer that undo had removed. The previous layer of audio begins playing back as you last heard it.

Erase a Track

1. Select the track you want to erase.
2. Press and hold the TRACK footswitch.
3. After about a second you will see both the TRACK LED and selected Track button blink. Continue to hold down TRACK (for about one more second) until the TRACK LED stops blinking.
4. You may now release the footswitch as the track has been erased. You can UNDO the Track Erase by pressing the UNDO footswitch.

Erase a Loop

1. Press and hold both the TRACK and UNDO footswitches.
 2. After about one second, all the Track buttons blink. Continue to hold down the footswitches for about another second until the LEDs stop blinking. You may now release the footswitches. The loop has been erased.
- **CAUTION:** You cannot undo a loop erase. Once you erase a loop it is gone forever (unless you backed it up onto a computer).

Record 2 Tracks Simultaneously (Stereo):

1. Press and hold both buttons of the stereo pair that you want to record. Stereo mode is enabled immediately upon pressing the second button in the pair. You should see the two tracks in the stereo pair lit up.
2. After connecting to the L and R INPUT jacks, adjust the INPUT Level knobs so that the CLIP LEDs barely light. The L INPUT records to odd numbered tracks only; R INPUT records to even numbered tracks.
3. Press the RECORD footswitch to begin recording immediately.
4. To stop recording, press either the RECORD or PLAY footswitches.

Record a Quantized Loop

1. Press the QUANTIZE button to enable Quantize mode. The button will light up.
 2. Turn the CLIX LEVEL knob up so you hear the metronome beat coming out of either the MONITOR or HEADPHONES output.
- **NOTE:** The CLIX metronome is not output through the L and R OUTPUT jacks.
3. The metronome tempo may be adjusted by the TEMPO slider or by tapping in a tempo with the TAP button. When the tempo is changed, the display will briefly show the tempo in BPM.
 4. Press the RECORD footswitch. The 95000 will not immediately begin recording but instead will give you a 1-bar count-in, where beat 1 of the bar occurs at the moment you press RECORD. After the Count-In is complete, the 95000 begins recording on beat 1 of the following bar.
- **NOTE:** The Count-In bar length may be adjusted or disabled.
5. During Count-In, the bars count down and the beats count up with a minus sign in front of the bar number. The Track 1 button also blinks rapidly.
 6. The 95000 begins recording at the end of the Count-In, as indicated by the flashing Track 1 button going solid and the minus sign being removed from the display.
 7. Stop recording by pressing either the RECORD or PLAY footswitches. Press RECORD or PLAY within the first 2 beats of the current bar and the 95000 will truncate the loop length to the end of the previous bar. Press RECORD or PLAY during the 3rd or 4th beats of the current bar and the 95000 will finish recording the current bar and then stop recording. For example, if you want to record a 2 bar loop, you can press the PLAY button during the 3rd and 4th beat of the second bar or within the first 2 beats of the third bar. The QUANTIZE button will blink rapidly until the loop has finished recording.

MIXING

Prepare to Mix

1. You can mix your 6 tracks down to one stereo Mixdown track at any time. For now, let's start with the 95000 in Idle (stopped) mode. If the 95000 is playing or overdubbing a loop, press the PLAY footswitch to stop.
 2. Press the MIXDOWN button once and it will light solid to indicate that the Mixdown track has been enabled for overdubbing.
 3. Press the PLAY footswitch. Your loop will play back. Move the Volume and Pan controls of the 6 tracks to establish a satisfactory balance.
- **NOTE:** You can adjust the Volume and Pan controls as much as you like when recording the Mixdown track.

Perform a Mix

1. When you are ready to record the Mixdown track, press the RECORD footswitch. You will immediately begin recording your mix onto the Mixdown track.
 2. The Mixdown track records the audio output from the 95000's mixer, enabling you to record your volume fader and pan movements as you hear them.
 3. To stop recording the Mixdown track, press either the PLAY or RECORD footswitch.
 4. Move the Mixdown slider up, move all of the track sliders down. Press PLAY to hear the newly recorded mix.
- **NOTE:** The original audio on the 6 mono tracks remains after you complete a mixdown. In other words, the mixdown operation does not erase the 6 tracks. The Dry Input signal is not recorded to the Mixdown track. Only audio that was previously recorded onto the 6 tracks will be recorded to the Mixdown track.

RESTORE FACTORY SETTINGS

To restore your 95000 to its original factory setting: press and hold the REVERSE button for 5 seconds or longer until you see some of the TRACK buttons blink and all three small LEDs below the Display are unlit.

- Restoring the 95000 factory settings has NO effect on the audio loops you store on the microSDHC card.

BASIC TERMINOLOGY AND KEY CONCEPTS

ERASE: The act of deleting an entire loop, one track, or a stereo pair of tracks when a stereo pair is enabled.

- You cannot undo a loop that has been erased. Once a loop is erased it is permanently deleted.
- To erase an entire loop do one of the following:
 - Press and hold the TRACK and UNDO footswitches simultaneously for two seconds. After the Track LEDs stop blinking, the loop is erased.
 - Press the NEW LOOP button while the loop is idle or in playback. Then press the RECORD footswitch to begin recording. Once you press the RECORD footswitch, the old audio that was at the current loop location is erased.
 - While recording a New Loop, press the NEW LOOP button to abort the recording and immediately erase the tracks.
- The 95000 does allow you to undo/redo a Track Erase.

IDLE: Equivalent to stop. When idle, the 95000 is not playing, recording or overdubbing.

LOOP: A loop is made up of 6 mono tracks and one stereo Mixdown track. All tracks are the exact same length.

- Think of a loop in terms of multi-track tape: the 6 tracks and the Mixdown track in a 95000 loop always playback, overdub or record in parallel, at the same speed and in the same direction. The one exception to this rule occurs with the use of Constant Tempo Mixdown mode, as described later in this manual.
- Loops are recorded and played back directly from the inserted microSDHC card.
- Up to 100 loops can be stored on one card.
- Upon creating a New Loop, the audio for all 6 mono tracks and the Mixdown track are established on the microSDHC card as silence; they take up space on the card even though you haven't actually recorded those tracks yet.
- Recording time: The total recorded audio time; varies with size of microSDHC Memory Card.
- Loop time: The actual loop length time that you can record. The loop length time will always be less than the total recording time. This time difference occurs because each loop consists of 6 mono tracks and the stereo Mixdown track, and every loop you record has all seven of these tracks as .WAV files at equal length.

OVERDUB/OVERDUBBING: The recording of any track after the initial recording of a New Loop. The RECORD and PLAY LEDs are both lit but the PUNCH button is off. Overdubbing can mean:

- Recording on a track—other than Track 1—that has not been previously recorded.
- Layering notes or instruments on top of each other on one track or a stereo pair of tracks. The tracks' DUB setting acts like a feedback control that may attenuate any previously recorded audio with each loop cycle.

QUANTIZE: A mode that allows the user to create loops that are exact bar lengths. Let's imagine you need to create a loop that is exactly 3 bars long. Enable Quantize mode to help make this happen.

- In Quantize mode, the 95000 starts and stops new-loop recording automatically.
- When using Quantize mode, it is best to listen to the 95000's built-in CLIX metronome or synchronize the 95000 to an external device that will produce a beat so you know exactly when recording will stop and start.
- By factory default, when Quantize is enabled, a loop begins recording after a one bar Count-In. You can change the number of bars of the Count-In to up to 8 bars, or you can disable the Count-In altogether.
- When Quantize is disabled, you are able to create loop lengths that are completely freeform. Loop recording starts immediately upon pressing either RECORD or PLAY footswitch and ends immediately upon pressing either RECORD or PLAY footswitch.

RECORD: The act of recording a New Loop. When stereo is disabled, the audio is recorded to Track 1. If stereo is enabled, the audio is recorded onto Tracks 1 and 2.

TRACK: A track is a discrete or separate channel of loop audio that may be recorded, overdubbed or mixed independently from other tracks.

- All tracks in a loop are the same length.
- All tracks contained in a loop playback, record or overdub at the same speed and direction as the other tracks.
- Each loop contains 6 mono tracks and one stereo track.

UNDO/REDO:

Undo: The undo function allows you to remove the last overdub layer that was recorded on a track.

- The 95000 has one level of undo for each track. You can independently undo each track without affecting the other tracks.
- To perform an undo, first ensure the selected track is the one that you want to undo. Then press and release the UNDO footswitch. The LED above the UNDO footswitch lights to indicate that an undo has been performed for the selected track.
- If you press the RECORD footswitch to overdub after performing an undo on a given track, the audio layer removed by the undo function will be permanently deleted and cannot be retrieved.

Redo: After performing an undo, restore the layer of audio that was removed by initiating the redo function.

- To perform a redo, first ensure the selected track is the one that you want to redo. Also, ensure that the UNDO LED is lit—if it is not, there is nothing to redo. Then press and release the UNDO footswitch to perform the redo.
- The redo function restores only the last layer of audio that undo removed.

MONITORING



Use the monitoring controls to vary the listening volume of various signals. None of the following monitoring controls affect the actual recorded signal levels.

1. DRY OUTPUT L/R Faders and Pan Knobs

The DRY OUTPUT faders and pan knobs allow you to monitor your instrument when recording or to play along with a loop you have already recorded. Adjust the output volume of your instrument with the DRY OUTPUT fader. Use the pan knobs to direct the Left and Right Inputs to the Left and Right Outputs. When pan is set to the full CCW position, the Input is monitored at the Left Output. When pan is set to the full CW position, the Input is monitored at the Right Output. When pan is set to the center-detent middle position, the Input is mixed equally to both Outputs. When monitoring a stereo signal, you will generally position the pan pots hard left and hard right. The settings of the DRY OUTPUT faders and pan pots have no influence on the actual recorded signal.

- When recording in mono, both inputs are summed together and recorded onto the same track. When recording in stereo, the two inputs remain separate: the Left Input is sent to the odd-numbered tracks and the Right Input is sent to the even-numbered tracks.

2. CLIX LVL Knob

Use the CLIX LVL knob to set a comfortable volume level for the CLIX metronome within the monitoring chain.

- The CLIX metronome is routed to the MONITOR OUT and Headphones outputs only. The CLIX metronome is not present at the L and R OUTPUT jacks.

3. HEADPHONE LVL Knob

The HEADPHONE LVL knob adjusts the output volume of the rear-mounted Headphone Output jack and the MONITOR OUT jack. The HEADPHONE LVL knob is an analog knob placed in the signal path *after* the 95000's D/A Converter. Therefore, it has no bearing on the level of the recorded audio that is saved to the microSDHC card. The signal at the MONITOR OUT jack is fed from the headphone amplifier, and so you must turn up the HEADPHONE LVL knob to hear audio at the MONITOR OUT jack.

4. MASTER LVL Knob

This knob is a master volume control for all signals and output jacks including the Loop, Dry levels and CLIX levels, as well as the L, R, Headphone and MONITOR Output jacks. MASTER LVL does not control the AUX IN volume.

THE RECORD TRANSPORT



1. INPUT LEVEL L/ R Knobs and CLIP LEDs

Use the INPUT LEVEL L and R knobs to adjust the amplitude of the left and right input signals before they are sent to the A/D Converter. To set the proper level, turn each INPUT LEVEL knob clockwise to the point where the maximum level causes the CLIP LEDs to barely blink or not light up at all. These LEDs light up when the audio signal clips—or is on the verge of clipping—the A/D Converter. In other words, the CLIP LEDs light when the signal's amplitude is greater than what the A/D Converter can properly handle. The L LED lights when the LEFT Input clips and the R LED lights when the RIGHT Input clips.

The trick to achieving the best quality digital audio is to record the hottest possible signal without clipping (overloading) the A/D converter. Typically, you want to record a signal that is neither too low in volume nor a signal that clips very often (unless that is the sound you are going for).

- **NOTE:** When recording in mono, both the Left and Right inputs are summed together and recorded onto the active track.
- Minimize hiss when recording in mono by turning down the unused INPUT LEVEL knob.

2. NEW LOOP Button

Press the NEW LOOP button to put the 95000 into Record-Ready mode. The NEW LOOP button lights green whenever the currently selected loop is empty. Upon pressing NEW LOOP, the red RECORD LED above the RECORD footswitch blinks to indicate that the 95000 is ready to record. Press the NEW LOOP button again if you decide you want to exit Record-Ready mode. Press the RECORD footswitch to begin recording a New Loop. If the Loop had been previously occupied with audio, the old audio is immediately erased upon pressing the RECORD footswitch. If you press the NEW LOOP button while recording a New Loop, the recording is canceled and whatever you recorded up to that point is discarded. Use the table on the next page to explore how pressing the NEW LOOP button acts depending on the current mode of the 95000.

Current Mode	+ NEW LOOP press	NEW LOOP LED state
Idle	Record-Ready	ON
Playback	Record-Ready; continues playing loop	ON
Overdubbing	Overdubbing; NEW LOOP Button is ignored	OFF
Record-Ready	Reverts to previous mode before Record-Ready	OFF
Recording New Loop	Cancels New Loop recording and discards the audio that had been recorded; loop remains empty	ON

3. TRACK Footswitch

Use the TRACK footswitch to advance tracks, erase tracks or to erase an entire loop.

Advance Tracks

Each press and release of the TRACK footswitch advances to the next track or pair of tracks and simultaneously activates the newly selected track(s). The buttons associated with each track or pair of tracks light green when active.

Erase Tracks

Erase a track so that it plays silence. Typically, the Track Erase procedure takes about 2 seconds:

- Select a track (or stereo pair).
- Press and hold the TRACK footswitch until the TRACK LED and the active Track Select button(s) blink rapidly.
- Keep holding the TRACK switch until the LEDs stop blinking; the track is now erased.
- To abort the erase track operation, release the TRACK switch early, either while the LED is blinking or prior to the start of it blinking.
- Tracks can be erased while the 95000 is idle, playing-back or overdubbing.
- A track-erase operation can be undone in the same way as a regular recording. See **Undo/Redo** later on this page.

Erase a Loop

Completely erase (delete) a loop, including the contents of the loop's folder on the microSDHC card. Once this action is performed, you CANNOT use UNDO to restore an erased loop.

- Simultaneously press and hold the TRACK and UNDO footswitches until the TRACK LED and all track-select buttons start to blink rapidly.
- Continue holding the TRACK and UNDO footswitches until the LEDs stop blinking. Once the LEDs extinguish, the loop has been erased. The NEW LOOP button lights up green to indicate the loop is empty.
- To abort the erase operation, release the TRACK and UNDO footswitches *before* the buttons stop blinking.

Abort New Loop Recording

While recording a New Loop, you may abort the recording and delete all audio files just recorded by simultaneously pressing both the TRACK and UNDO footswitches. Once both footswitches are pressed, the New Loop recording will be aborted. The audio files are permanently deleted.

4. UNDO Footswitch

The 95000 supports one level of undo/redo per track. This functionality allows the last recorded audio layer on a given track to be removed and then subsequently restored. Each track's UNDO operation is independent from the other tracks.

Undo/Redo

Press and release the UNDO footswitch to undo the last recording or overdub layer on the currently selected track. You can select and undo either a mono track, a stereo-pair track or a Mixdown track. If only one layer of audio has been recorded on the track, pressing UNDO will cause the track to play back silence.

Press and release the UNDO footswitch again to restore (REDO) the last recording/overdub layer that had previously been undone.

- The UNDO footswitch can be pressed while the 95000 is idle, playing or overdubbing. If you are overdubbing, the 95000 will switch to playback mode and then undo the last overdub on the currently selected track. Press the UNDO footswitch again to redo/restore the previous overdub.
- The green LED just above the UNDO footswitch lights if an undo operation has been performed on the currently selected track. A lit UNDO LED indicates that redo could be performed. Press UNDO again to redo/restore the last audio layer; the UNDO LED turns off.

5. RECORD Footswitch

Depending on the 95000's current mode, the RECORD footswitch serves a few purposes, all of which enable the 95000 to enter/exit one of the recording modes: Record, Overdub or Punch-In. The red RECORD LED will light up solid anytime the 95000 is recording or overdubbing audio. The RECORD LED blinks at a medium rate when the 95000 is in Record-Ready mode. The table below explains the result of pressing the RECORD footswitch in relation to the current mode of the 95000.

Current Mode	+ RECORD	Record LED State
Idle (no loop in memory)	Begin Recording New Loop	LED ON
Idle (with loop in memory)	Overdubbing	LED ON
Playback	Overdubbing	LED ON
Overdubbing	Playback	LED OFF
Record-Ready	Begin Recording New Loop	LED ON

6. PLAY (□▷) Footswitch

The PLAY (□▷) footswitch is used to toggle Playback on and off. The green PLAY LED will light anytime the 95000 is playing or overdubbing audio. The table below explains the result of pressing the PLAY button in relation to the current Record/Playback mode of the 95000. **NOTE:** Each time a loop cycles back to the beginning, the PLAY LED blinks once to signify the start of the loop.

Current Mode	+ PLAY	Play LED State
Idle (no loop in memory)	Idle, No Change	LED OFF
Idle (with loop in memory)	Playback	LED ON
Playback or Overdubbing (Fade-out disabled)	Idle	LED OFF
Playback or Overdubbing (Fade-out enabled)	Fade-Out	LED BLINKS until fade-out is complete, then LED OFF
Record-Ready (loop in memory)	Playback of current loop if it contains audio	LED ON
Recording New Loop	Overdubbing, sets loop length	LED ON

7. LOOP ▽△ Selection Footswitches

Loop selection is incremented or decremented using the LOOP UP △ and LOOP DOWN ▽ footswitches. Press and hold either footswitch to advance through the loops at a faster speed. The table below explains the result of pressing the LOOP UP △ and LOOP DOWN ▽ footswitches in relation to the current mode of the 95000. **NOTE:** You can also change the current loop by using the VALUE knob. Refer to the LED DISPLAY AND CONTROL section later in this manual to learn about the use of the VALUE knob.

Current Mode	+ LOOP △ or ▽
Idle	Loop increments or decrements by one with each press and release of the LOOP △ and ▽ footswitches.
Playback	Current loop continues to play. Loop increments or decrements and loop display number blinks. If the blinking loop number contains audio, the New Loop number begins playback when the old loop reaches its end point. If the blinking loop number has no audio, the old loop continues playing indefinitely.
Overdubbing	Overdubbing (no change)
Record-Ready	Cancels Record-Ready. Loop increments or decrements by one with each press and release of the LOOP △ and ▽ footswitches.
Recording New Loop	Recording New Loop (no change)

8. PUNCH Button

Press the PUNCH button to enable/disable PUNCH (“Punch-In”) mode. While recording with Punch-In enabled, all audio previously recorded on the active track is erased each time the loop cycles. The Punch-In function is particularly useful for fixing bad notes or mistakes. When Punch-In mode is active, the PUNCH button lights green.

9. OCT Button

The OCT (Octave) button lowers the speed of the loop by exactly one-half: the pitch will go down one octave and the tempo will be halved. The OCT button can be used at all times except when recording a New Loop or when syncing to external MIDI Clock. The OCT button lights green when the Octave function is active.

10. REVERSE Button

Press the REVERSE button to reverse the loop’s playback/overdub direction. Reverse can be used at all times except when recording a New Loop. The REVERSE button lights green when the reverse function is active.

With EXT. CLOCK activated, if you press the REVERSE button while the 95000 is playing or overdubbing, the Reverse function will activate. But the 95000 will most likely lose its place within the bar, even though its tempo is still synchronized to the external MIDI clock. In situations where you want a Reverse loop to remain synchronized to the bar, we recommend you stop loop playback, toggle the REVERSE button, and then begin loop playback.

11. EXT. CLOCK Button

Press the EXT. CLOCK button to synchronize the 95000 with external MIDI Clock messages received at the MIDI IN jack. With each press of the EXT. CLOCK button, the 95000 cycles through the following modes of synchronization:

- **IN (EXT. CLOCK Button OFF):** Internal Clock Sync mode. The 95000 uses its internal clock for loop speed. Either the TEMPO slider, TAP button, or both set the tempo or loop speed. This mode should be employed if the 95000 is used on its own or is the MIDI Clock master for a slave device.
- **XT (EXT. CLOCK Button LIT):** Full External Clock mode. The 95000 is in full external clock mode—it synchronizes to an external device’s MIDI Clock and responds to MIDI Start, Stop and Song Position Pointer (SPP) commands. This mode is recommended for most situations where the 95000 needs to synchronize to an external device.

- **BX (EXT. CLOCK Button BLINKS):** Beat Sync External Clock mode. The 95000 synchronizes the loop tempo to an external device’s MIDI Clock but ignores the MIDI Start command. When a MIDI Start command is received from the MIDI master, the 95000 follows external MIDI Clock and resets to beat 1; but it does not begin playback of its loop. You must press PLAY on the 95000 to start playback. Playback will start from the beginning of the loop on the next MIDI Clock beat received from the master device. To begin playback of the loop on the MIDI master’s beat 1, press the PLAY footswitch just before you hear beat 1 from the MIDI master.

12. QUANTIZE Button

The QUANTIZE button toggles between Quantize and Non-Quantize (NQ) modes. The QUANTIZE button lights when the 95000 is in Quantize mode.

QUANTIZE Mode Use Quantize mode to create loops that are exact bar lengths. When you create a New Loop in Quantize mode, there will be a Count-In of up to 8 bars. The factory default is 1 bar; Count-In can also be disabled. After the Count-In, the loop begins recording on beat 1. When ending a loop, the loop length is either extended or truncated to the nearest full bar. In Quantize mode, you can be sloppy about ending the loop; the 95000 adjusts the loop length to the nearest bar to yield loops that cycle perfectly in sync with the CLIX metronome. A bar may be 1-8 beats in length (factory default is 4). To change the number of beats per bar:

- First select the BARS/BEATS page with the PAGE button.
- Then press and hold the VALUE knob. The display changes to “BAR” followed by a blinking number. This number indicates the number of beats in a bar.
- Rotate the VALUE knob to change the number of beats in a bar.
- Press the VALUE knob to save the setting and exit.

NON-QUANTIZE Mode: The length of the loop is defined by the time between pressing the RECORD footswitch to begin recording and then pressing the RECORD or PLAY footswitch to end the loop.

- When setting the 95000 to EXT. CLOCK mode, we recommend you enable Quantize mode. If Quantize is not enabled, the loop lengths will not line up with the MIDI master device’s bar lengths. This misalignment will cause the loops to sound out of sync even though the loop’s tempo is actually in sync with the MIDI Clock master.

TRACKS, TRACK SELECTION, MIXDOWN, TEMPO

TRACKS OVERVIEW

- There are 6 tracks available for you to record your instruments and vocals.
- You can record a maximum of 2 tracks simultaneously.
- Each of the 6 tracks contains a volume fader and pan knob to balance your levels and place your tracks within the stereo spectrum.
- Each track also contains an illuminated button above each track number. When a button is lit, that particular track is active. Press the RECORD footswitch to record an overdub on the active track.
- The tracks are available in mono or stereo pairs (1 & 2, 3 & 4 or 5 & 6).

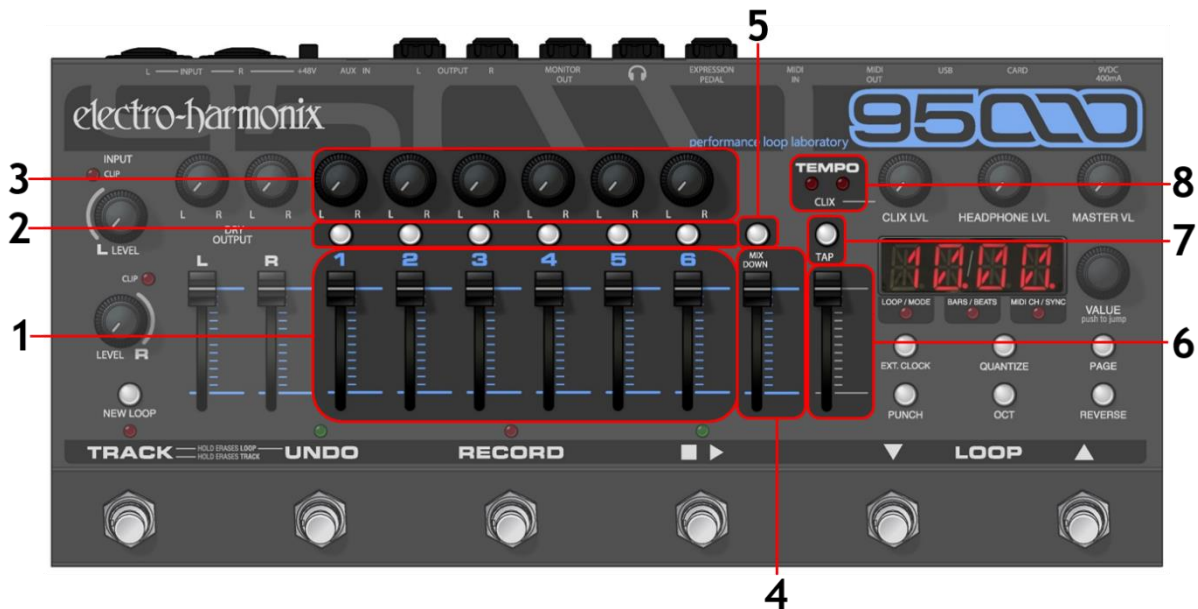

1. TRACK Faders

The Track faders independently control the playback level of each track.

2. TRACK SELECT Buttons

The illuminated Track Select buttons (1-6) are used to select mono or stereo pairs of tracks for recording, overdubbing, and other functions such as Track Erase and undo/redo. Press a Track Select button to activate a track. Simultaneously press a pair of Track Select buttons (1 & 2, 3 & 4 or 5 & 6) to enable stereo tracks. Press and hold a pair of track buttons to toggle between mono and stereo track selection. Press the TRACK footswitch to advance the currently selected track or pair of tracks. The Track Select buttons illuminate to indicate they are selected.

MIXDOWN Track

The MIXDOWN track is a stereo track that records the audio from the six mono tracks through their pan knobs and faders. Use the Mixdown track to create a stereo mix, bounce tracks or create special effects. The Mixdown track is automatically set to the exact same length as the six mono tracks. There are two modes of Mixdown: Normal Mixdown and Constant Tempo Mixdown.

3. TRACK PAN Knobs

The Track Pan knobs allow you to place Tracks 1-6 to the left and right outputs.

4. MIXDOWN Fader

The MIXDOWN fader controls the volume of the Mixdown track.

5. MIXDOWN Button

The MIXDOWN button gives you access to the Normal and Constant Tempo Mixdown modes. Use Normal Mixdown mode when you want to bounce the 6 mono tracks or create a clean stereo mix. Use Constant Tempo Mixdown mode to create pitch-related special effects.

- Enter Normal Mixdown mode by pressing the MIXDOWN button once. When in Normal Mixdown mode, the MIXDOWN button lights solidly. Normal Mixdown can be selected while the 95000 is overdubbing, playing or idle.
 - You can use the TRACK footswitch to enter Normal Mixdown mode if the 95000 is idle.
 - Constant Tempo Mixdown may only be entered while the 95000 is idle. If the MIXDOWN button is off, press it twice to activate Constant Tempo mode. In Constant Tempo mode the MIXDOWN button blinks rapidly.
 - Use Constant Tempo Mixdown mode to add flanging or pitch-bending effects to your Mixdown track. The Mixdown track records at a constant speed or tempo, but the TEMPO slider allows you to vary the speed of the 6 recorded tracks. As the Mixdown track is recorded, the speed variations you perform with the TEMPO slider will be recorded onto the Mixdown track. Create subtle effects such as flanging, or more drastic effects that feature radical pitch bending.
 - To EXIT either Mixdown mode, press the MIXDOWN button (while the 95000 is idle) until the MIXDOWN LED turns off. You can also exit Mixdown mode by pressing any of the Track Select buttons or the TRACK footswitch.
- See the **IN DEPTH: MIXDOWN** section of this manual for a complete overview of Normal and Constant Tempo Mixdown modes.

6. TEMPO Slider

When the 95000 runs off of its internal clock (External Clock Sync mode is disabled), the TEMPO slider may be used to set a loop's tempo or BPM as well as the tempo of the CLIX metronome. If the currently selected loop is empty, the TEMPO slider ranges from 60 BPM to 240 BPM in 1 BPM increments. The tempo increases as the slider is pushed up, and decreases as the slider is pushed down.

After recording a New Loop, the integrated TAP button lights up solidly. This lit button shows you that the TEMPO slider is set to the original tempo at which the loop was initially recorded. The TAP light shuts off when the tempo is set to anything other than the original tempo.

Two options are available to adjust the action of the TEMPO slider on recorded loops: **COARSE** or **FINE**. Enter the Secondary Mode pages mode (see the **LED DISPLAY AND CONTROL** section later in this manual) to choose either COARSE or FINE mode. The factory default is COARSE.

- **COARSE Mode:** the TEMPO slider increments tempo and pitch in semitone (1/2) steps. To illustrate how this works, imagine you record a loop in the key of E and then push the TEMPO slider upwards. You will hear the speed of the loop change in discrete 1/2 steps. Thus, going upward to the next position plays the loop in the key of F. The next position upward is F#, and so on.
- **FINE Mode:** the TEMPO slider changes tempo and pitch in one BPM increments between 60 BPM and 240 BPM. If the OCT button is lit, the tempo ranges from 30 BPM to 120 BPM.

To use the TEMPO slider to create pitch changing and bending effects:

- After you have recorded a New Loop, move the TEMPO slider (and/or press the OCT button) on subsequent tracks to record notes at different speeds. When played back at the loop's original speed, the pitch of the notes will change accordingly. For example, record Track 1 with some guitar chords. Move the TEMPO slider up one octave and record some single low notes with the same guitar. Play both tracks back at the original tempo and you will have guitar and bass tracks.
 - While recording, try moving the TEMPO slider. When you play the loop back at a set tempo, the notes will bend opposite to how you moved the TEMPO slider during recording.
- Whenever the TEMPO slider is moved, the display momentarily shows the current BPM. The display continues to show the BPM setting for two seconds after you stop moving the TEMPO slider.

7. TAP Button

In addition to moving the TEMPO slider, you can also change tempo by pressing the TAP button two or more times to put the 95000 into Tap Tempo mode. The 95000 produces a set tempo by calculating the average of the four most recent taps in a grouping of TAP button presses. The TAP button's integrated LED blinks at the current tempo.

- In normal use, Tap Tempo ranges from 60 BPM to 240 BPM. The TEMPO slider can then adjust the tempo from half the current tap tempo, with the slider fully down, to twice the current tempo with the slider fully up—maxing out at a tempo of 240BPM. The original tap tempo setting is located at the TEMPO slider's center position. The TEMPO slider position is activated when it is first moved after tapping in the tempo.
- Tempo changes entered with the TAP button are shown on the LED display for 2 seconds.

- To view the current tempo (in BPM) on the LED display, press the TAP button once.
- Press the PAGE and TAP buttons at the same time to cancel Tap Tempo mode and return tempo control to the TEMPO slider.

8. CLIX LEDs

The CLIX LEDs blink on the beat at the tempo to which the 95000 is set. The left LED lights briefly on every beat; the right LED only blinks on the first beat of a bar. When the 95000 uses its internal tempo, the TEMPO slider and/or TAP button set the tempo at which the LEDs blink. When EXT. CLOCK is activated, the CLIX LEDs blink at the received MIDI Clock tempo.

- Use the CLIX LEVEL knob to adjust the volume of the built-in CLIX metronome.

LED DISPLAY AND CONTROL



1. LED DISPLAY

- The 4-digit LED display provides visual feedback and control for a number of functions. These functions are accessible by cycling the display through three Primary Mode pages and four Secondary Mode pages. Press and release the PAGE button to cycle through these Primary Mode pages: LOOP/DUB, BARS/BEATS, MIDI CH/SYNC. Press and hold the PAGE button to access the Secondary Modes.
- Each Primary Mode page is indicated by the small round LED that lights below the display.
- The Secondary Mode pages are indicated when the PAGE button blinks rapidly and all three LEDs below the main display are off.
- Each Primary Mode page displays two parameters. The left parameter is active by default. A dot in the bottom right-hand corner of the display indicates that the right parameter is active. Press and release the VALUE knob to toggle between activating the left or right parameter.
- The LED display may also be used to display tempo change. When you move the TEMPO slider or tap in a new tempo with the TAP button, the display momentarily displays the new tempo in BPM for two seconds, and then the LED reverts to the previously-set function. All lit PAGE LEDs turn off during tempo display.

2. VALUE Push to Jump Knob

The VALUE knob modifies the active parameter. Push/click the knob to toggle between the left and right parameters. Turn the knob to change the value of the selected parameter.

3. PAGE Button

Press and release the PAGE button to cycle the LED display through the three Primary Pages: LOOP/DUB, BARS/BEATS, and MIDI CH/SYNC.

Press and hold the PAGE button for one second to access the Secondary Mode pages: CX (CLIX), TM (TEMPO slider), CT (Count-In) and FD (Fade-Out). Press and release the VALUE knob to cycle through these four pages. Turn the VALUE knob to change the setting of the displayed parameter. Press and release the PAGE button to exit Secondary Mode.

PRIMARY MODE PAGES

4. LOOP/DUB Mode

The LOOP/DUB page shows the current loop number and the active track's overdub feedback level.

- The left field displays the selected loop number. Turn the VALUE knob or press the LOOP Up and Down footswitches to select a different loop.
- The right field shows the DUB feedback level for the active track(s). The feedback level ranges from 0 to 10, which equates to 0% to 100%. While overdubbing on a track, the number in the DUB field determines the volume level of the previously recorded portion of the loop that is recorded back onto the currently recorded loop. Each value between 0 and 10 allows you to reduce the volume of previously recorded audio; the lower the number, the quieter the previously recorded audio will be for each overdub cycle. Set DUB to 10 for no volume reduction with each overdub cycle. When DUB is set to 0, previously recorded audio will be fully erased with each loop cycle.

- **PRO TIP:** Set DUB to a value under 10 and the looper acts as a type of digital delay in which the loop length equals the delay time.

Loop Status: The middle dot next to the loop number indicates the loop status:

- Off = no loop (NEW LOOP button will also illuminate)
- Blinking = loop loading
- On = loop present and ready

5. BARS/BEATS Mode

The BARS/BEATS page displays the current position of the loop in bars and beats.

- The three-digit field to the left of the dot shows the current bar number.
- The single-digit field to the right of the dot represents the current beat number.
- The 95000 temporarily switches to BARS/BEATS display mode while recording a New Loop.
- When Count-In is set to a bar length between 1 and 8 and the QUANTIZE button is lit: during the New Loop Count-In period the display counts down the bars while the beats count up. The minus sign before the BARS number indicates that the 95000 is performing the Count-In.
- While a loop is playing or idle, turn the VALUE knob to move the loop to a specific bar and

beat location. If you turn the VALUE knob while the loop is playing, the 95000 will jump to the new location and continue playback. When you stop a loop, the loop automatically goes back to the beginning of the loop (position 1.1). You cannot jump to a new location while the loop is recording or overdubbing.

- **BEATS PER BAR:** The number of beats per bar may be set to a number between 1 and 8. The factory default is 4 beats per bar for a 4/4 time signature. To change the number of beats per bar, press and hold the VALUE knob for two seconds until "BAR x" appears in the display. The blinking "x" will show the current number of beats per bar. Turn the VALUE knob to adjust the number of beats. Press and release the VALUE knob to save the new setting and return to BARS/BEATS mode. To save the new beats per bar setting for all future loop recordings, set the number of beats per bar on an empty loop. You may change the beats per bar setting on a loop after it has been recorded, but only that loop's setting will be updated.

6. MIDI CH/SYNC Mode

Select the MIDI CH/SYNC page to view and adjust the MIDI Channel and Sync options. The parameter on the left indicates the MIDI receive channel 01-16 or OM (Omni) for Program Change (PC) and Control Change (CC) messages. The right parameter displays the Sync mode.

SYNC Modes

In

Choose the IN setting to select Internal Clock Sync mode. In this mode, the 95000 uses its own tempo as set with either the TEMPO slider or the TAP button, and External sync is disabled.

External

- XT = Full External Clock mode: the 95000 receives and responds to MIDI CLOCK, START, STOP and SPP messages.
 - BX = Beat Sync External Clock mode: the 95000 only responds to MIDI CLOCK and STOP messages; it does not respond to MIDI START or SPP messages.
- Cycle through the Sync options at any time by pressing the EXT. CLOCK button.
 - The EXT. CLOCK button blinks in BX mode.
 - To fully explore how to use either Sync option, see the **MIDI Sync** section of this manual.

SECONDARY MODE PAGES

- Press and hold the PAGE button for about one second to activate the Secondary Mode pages. The PAGE button will blink rapidly and the red Primary Mode LEDs will be unlit. Once Secondary Mode has been entered, release the PAGE button.
- Press and release the VALUE knob to cycle through the four available pages. Then turn the VALUE knob to change a specific parameter.
- Exit Secondary Mode at any time by pressing the PAGE button. The PAGE button will no longer be lit.
- New settings are global; they affect all loops and are saved in internal memory so that the 95000 recalls your last used settings during power up.

Once in Secondary Mode, select the following functions and manipulate their associated parameters:

CLIX Metronome

1. **CX.ON:** The CLIX metronome runs continuously (default).
2. **CX.PL:** The CLIX metronome only sounds when a loop is playing or recording; when the loop is stopped, the CLIX metronome is muted.
3. **CX.NL:** The CLIX metronome only runs while recording a New Loop; when not recording a New Loop, the CLIX metronome is muted.

TEMPO Slider Resolution

Sets the “action” of the TEMPO slider after a loop has been recorded and EXT. CLOCK is disabled:

1. **TM.CR:** The TEMPO slider resolution is COARSE, and the loop speed changes in semitones (default).
2. **TM.FN:** The TEMPO slider resolution is FINE and changes in one BPM increments.

Count-In

Count-In only occurs prior to a New Loop recording and when QUANTIZE is enabled:

1. **CT.OF:** Count-In is disabled (or OFF).
2. **CT.01-08:** Count-In is enabled. The number of Count-In bars is represented by the number shown in the display. The default setting is 1 bar.

Loop Fade-Out

Upon stopping loop playback, the 95000 has the option to either stop immediately or to continue playing the loop while the loop volume fades out. The loop then stops playback when the volume hits zero. If you would like the loop volume to fade-out gradually, set this parameter to a number between 1 and 99.

1. **FD.OF:** Loop fade-out function is disabled (default).
2. **FD.01-99:** Loop fade-out is enabled, and the loop fade-out time (in seconds) is indicated by the number in the display.

REAR CONNECTIONS AND CONTROL



1. 9VDC 400mA Power Jack

Connect the output plug of the factory-supplied AC Adapter into this 9VDC power jack. The current requirement is 400mA at 9VDC. The polarity of the power jack is **center negative**. The maximum allowable power supply voltage is 10.5 VDC.

Once power is applied, the 95000 begins its startup procedure. The 4-digit LED display shows the following:

1. “EHX 95000” scrolls across the display.
2. Then the firmware’s version number “V x.y” will appear briefly to indicate the currently loaded software version.
3. Finally, the screen settles on the last used LOOP number and DUB setting for Track 1.

2. microSDHC Card Slot

Insert a microSDHC Memory Card in this slot to store your loops.

3. USB Connector

Plug a standard USB cable into this port to interface the 95000 with your computer.

4. MIDI OUT Connector

Use a standard 5-pin DIN MIDI cable with this connector. When the EXT. CLOCK function is off, the 95000 continuously generates MIDI Clock and outputs it through the MIDI OUT jack.

Connect to MIDI OUT when you want the 95000 to be the MIDI Clock master; you can slave another device, such as another 95000, drum machine, 8-Step Program sequencer, x0xb0x or beat box to the 95000.

When either of the EXT. CLOCK modes is enabled, the 95000 uses the MIDI OUT jack as a MIDI THRU jack. Whatever messages the MIDI IN jack receives are passed back through the MIDI OUT jack.

5. MIDI IN Connector

Connect a standard 5-pin DIN MIDI cable to this connector to receive MIDI Clock, Control Change (CC) and Program Change (PC) messages. When the EXT. CLOCK function is enabled, the 95000 can sync to MIDI Clock through the MIDI IN jack. You can use another 95000, a drum machine, sequencer, x0xb0x, beat box or any other device that outputs MIDI Clock as the MIDI Clock master; the 95000 will slave to the external device.

Using MIDI CC and PC messages, you can control nearly every parameter on the top panel of the 95000. The only controls not available via MIDI are the L and R INPUT LEVEL knobs and the HEADPHONE LVL knob.

6. EXPRESSION PEDAL Jack

Connect an expression pedal with a 1/4" TRS plug to the EXPRESSION PEDAL jack of the 95000. Use this pedal to control the Master Level of the loop audio. When an expression pedal is connected, the 95000 MASTER LVL knob sets the maximum volume that can be achieved with an expression pedal. The expression pedal only sweeps the volume of the loop audio—Tracks 1-6 and MIXDOWN. It does not sweep the volume of the DRY audio present at the two input connectors.

Accepted expression pedals include:

- Electro-Harmonix Expression Pedal
- Electro-Harmonix Dual Expression Pedal
- Electro-Harmonix Next Step Expression Pedal
- Boss® FV-500L
- Moog® EP-3
- M-Audio® EX-P

7. HEADPHONE Jack

Plug headphones into the 1/4" Stereo Headphone jack. Each channel of the Headphone jack can deliver 0.1W into 16 ohms. The Headphone jack contains the loop audio from all 6 main tracks, the Mixdown track, the DRY OUT channels, audio from the AUX IN jack and the CLIX LEVEL metronome beat. NOTE: the volume of the audio at this jack is set by the HEADPHONE LVL knob. The volume set by the HEADPHONE LVL knob is dependent on the setting of the MASTER LVL knob, which acts as a master volume control for all outputs.

8. MONITOR OUT Jack

This output produces a mono version of the signal present at the Headphone jack. The left and right channels of the headphones are mixed together into mono and then sent to this jack. The MONITOR OUT jack contains the loop audio from all 6 main tracks, the Mixdown track, the DRY OUT channels, audio from the AUX IN jack and the CLIX metronome.

- The overall volume of the audio at the MONITOR OUT jack is set by both the HEADPHONES LVL and MASTER LVL knobs. If either knob is fully turned down, no audio will come out of the MONITOR OUT jack.
- The output impedance at the MONITOR OUT jack is 400Ω.

9. L and R OUTPUT Jacks

The L (Left) and R (Right) OUTPUT jacks are the main outputs from the 95000. Connect these outputs to your amplifier, mixer, audio interface, tape recorder or any suitable device.

The L and R OUTPUT jacks contain the loop audio from all 6 main tracks, the Mixdown track, DRY OUTPUT L and R channels, and the audio signal input at AUX IN. The L and R OUTPUT jacks do not output the CLIX metronome nor are they affected by the setting of the Headphone volume knob. Note that the MASTER LVL knob is a master volume control for ALL outputs, including the L and R OUTPUT jacks. The output impedance at the L and R OUTPUT jacks is 400Ω.

10. AUX IN Jack

This 3.5mm stereo input is mixed with the stereo output of the 95000 in the analog domain and is output through the L and R OUTPUT jacks, the Headphone jack, and the MONITOR OUT jack. Connect a phone, mixer, drum machine—or any other device with a line output—and mix the signal directly with the loops of the 95000. The 95000 does NOT record audio from the AUX IN Jack. Since the input impedance presented at the AUX IN Jack is 9.5kΩ, it is best suited for devices with line level outputs. Set the output volume on your AUX IN device to mix it properly with the 95000 output.

11. +48V Phantom Power Button

When this button is pressed in, phantom power is applied to **both** XLR MIC input connectors. Phantom power is disabled with this button set to the “out” position.

- **CAUTION!** Please ensure your microphone can withstand phantom power (up to +48VDC) before engaging this switch. Certain ribbon microphones, in particular, are known to be susceptible to damage when used with phantom power.

12. L and R INPUT Combo Jacks

The L (Left) and R (Right) Inputs are combo jacks which accept either XLR or 1/4" connectors.

The XLR input is balanced and is primarily intended for microphones, although signals up to +4dBu in amplitude may be connected before clipping. The input impedance on the XLR input is 2.5kΩ.

The 1/4" input is a high impedance, unbalanced input intended for both instruments and line level signals. This input can accept signal amplitudes up to +9.8dBu. The input impedance presented at each 1/4" input is 2MΩ.

In Mono mode, either input can be used to record onto any of the 6 tracks. In Stereo mode, the Left Input records to the odd numbered tracks (either 1, 3 or 5) and the Right Input records to the even numbered tracks (2, 4 or 6).

IN DEPTH: RECORDING TRACKS

Prepare to Record a New Loop

1. Plug your instrument into either the L or R INPUT jacks, or both if recording two separate instruments or if recording in stereo.
2. To monitor your recording, connect one or both of the L and R OUTPUT jacks or the MONITOR OUT jack to a mixer or amp. You can also plug headphones into the HEADPHONES jack.
3. Play your instrument(s) and adjust the INPUT LEVEL knob(s) so that the associated CLIP LED does not light or just barely lights on your loudest notes. The trick to achieving the best quality digital audio is to record the hottest possible signal without clipping the A/D converter. You do not want to record a signal that is too low in volume or a signal that clips very often... unless that is the sound you are going for!
4. If recording only one input, turn down the unused channel's INPUT LEVEL knob fully to reduce hiss from the unused channel.
5. Use the DRY OUTPUT faders and pan knobs to adjust the level and stereo location of the two input signals when monitoring.
6. If using either Headphones or the MONITOR OUT jacks, a separate volume control is available just for these outputs. The HEADPHONES LVL knob adjusts the volume for both the Headphones output and the MONITOR OUT jack.
7. The setting of the DRY OUTPUT faders and pan knobs have no effect on what is actually recorded. Only the INPUT LEVEL knobs have any bearing on what is recorded.

Non-Quantize vs. Quantize Loop Recording

- **REMINDER:** Press the QUANTIZE button to toggle between Quantize and Non-Quantize modes. When the QUANTIZE button is lit, you are in Quantize mode.

In Non-Quantize Mode, the loop length is set by the user (i.e. manually). In Quantize Mode, the loop length is determined by the number of bars you wish to record, the beats per bar setting (found in the BARS/BEATS page), and the current tempo.

Non-Quantize Mode

The loop length consists of the time between pressing RECORD to begin recording a loop and pressing either the RECORD or PLAY footswitches to end the loop. The 95000 begins recording immediately upon pressing RECORD and ends loop recording immediately when you press either the RECORD or PLAY footswitch.

Quantize Mode

The 95000 automatically quantizes the loop length to the nearest bar. A bar may be 1-8 beats in length. The default length is 4 beats.

Upon pressing the RECORD button, the 95000 resets the CLIX metronome to beat 1.

If enabled, the Count-In begins and the display shows the Count-In bars with a minus sign in front of the bar number. No recording takes place during Count-In.

- **REMINDER:** You can set the Count-In length from 1-8 bars or disable Count-In altogether by setting the Count-In length to OF (Off).

The 95000 starts recording after the Count-In. To hear the CLIX metronome you must monitor through either MONITOR OUT or headphones and make sure both the CLIX LVL and HEADPHONE LVL knobs are turned up to an appropriate level.

Pressing the PLAY or RECORD footswitches ends the loop—but not necessarily at the exact moment you press either footswitch. Instead, the 95000 truncates the loop's length to the end of the previous bar if PLAY or RECORD are pressed within the first 2 beats of the current bar. When PLAY or RECORD are pressed after the 2nd beat, the 95000 will continue recording to the end of the current bar and then end the loop. You can record as few as 1 bar or as many as the microSDHC card will allow.

The CLIX metronome's tempo can be adjusted using the TEMPO slider or by pressing the TAP button at least twice. It is best to adjust the tempo while in Record-Ready mode, before pressing the RECORD footswitch.

If you discover that you normally work best in Quantize mode, feel free to always leave Quantize enabled. Otherwise, enable or disable Quantize prior to pressing the RECORD footswitch when recording a New Loop.

If you press the QUANTIZE button while in the process of recording a New Loop, you will be able to end the loop according to the rules of the Quantize mode you just entered. For example, you start a loop in Quantize mode so that you can have a 2-bar Count-In. But you want to end the loop in the middle of a bar. Press the QUANTIZE button while recording the loop; when you press the PLAY footswitch to end the loop, it will end immediately without either finishing out the bar you are recording or truncating the bar.

QUANTIZE mode has no effect on the state of the 95000 once you have recorded the New Loop and established the loop length.

Stereo Mode

In order to record in stereo, or to record two mono tracks simultaneously, Stereo mode must be enabled. Press and hold both Track Select buttons of a stereo pair to enter Stereo mode. Once you enter Stereo mode both buttons of the stereo pair will be lit. There are three stereo pairs: Tracks 1 & 2, 3 & 4 and 5 & 6.

Disable Stereo mode in the same way as you enable it: press and hold both buttons of a stereo pair. You can enable Stereo mode at any time. You will most likely want to enable stereo just before recording a New Loop or just before overdubbing tracks for an already established loop.

You can start a loop by recording mono instruments onto the tracks and then—at any time—switch to Stereo mode and begin recording stereo instruments onto the track pair. Conversely, you can start a loop by beginning to record it in stereo and then change to mono.

Record a New Loop

Now you should be ready to record a loop!

1. If you are on an empty loop, press the RECORD footswitch to commence recording. When either Quantize or Count-In are disabled, the loop begins recording immediately.
2. If the current loop already has audio but you would like to create a New Loop in its place,

press the NEW LOOP button to enter Record-Ready mode. The RECORD LED blinks.

3. If you need to exit Record-Ready mode, simply press the NEW LOOP button again.
 4. While in Record-Ready mode, choose between Quantize or Non-Quantize modes.
 5. Press the RECORD footswitch to commence recording. The LED will display bars and beats as the recording takes place.
- While recording a New Loop, the following buttons are inactive: REVERSE, OCT, EXT. CLOCK and MIXDOWN.
 - Moving the TEMPO slider while in the process of recording a New Loop will not change the pitch of the recording, although it would if you were performing an Overdub instead of recording a New Loop. In any case, we do not generally recommend moving the TEMPO slider while recording a New Loop. After the New Loop is recorded and the loop length is established, you can move the TEMPO slider all you like.

End a New Loop

To end a New Loop, press either the PLAY or RECORD footswitches. While recording a New Loop, if you decide you do not like the loop: press the TRACK and UNDO footswitches simultaneously OR just press the NEW LOOP button to immediately stop recording and discard the loop.

- By pressing the PLAY footswitch, the 95000 automatically enters Overdub mode. Both the RECORD and PLAY LEDs light up. The loop will cycle back to its beginning, and you will hear what you just recorded on Track 1. When pressing PLAY, the active track will move to Track 2 and you can immediately start recording onto Track 2.
- Upon pressing the RECORD footswitch, the 95000 immediately enters Play mode, the loop cycles back to its beginning and you will hear what you just recorded on Track 1. The PLAY LED lights up. The active track jumps to Track 2.
- Pressing the NEW LOOP button causes the 95000 to stop recording the New Loop and immediately discards whatever audio had been recorded.

Loop Length and Storage Capacity

The loop length is set automatically for all tracks in a given loop when you record a New Loop on Track 1. The loop length for any given loop is set when you record your New Loop, and the loop length for all 7 tracks is always identical to Track 1's length. For example, imagine you record a new 10-second loop: the length of all 7 tracks will be 10 seconds, too. You cannot record a longer or shorter loop on, say, Track 3 as compared to Track 1.

- **NOTE:** The shortest New Loop length you can record is 1.5 seconds.

Each microSDHC Memory Card in the 95000 can store up to 100 loops, regardless of the size of the card or the length of each loop. The audio for the loops is always recorded and played back directly from the microSD card. If you buy a second microSDHC card and insert it into the 95000, you will gain access to another 100 loops.

- For detailed information on loop length and storage, refer to the **Memory Card and USB** section later in this manual.

Change Loop Numbers

To change Loop Numbers: press the dedicated LOOP footswitches or turn the VALUE knob when set to the LOOP/DUB page.

The LOOP Up Δ footswitch increments the loop number by 1, and LOOP Down ∇ footswitch decrements the loop number by 1. Press and hold either LOOP Up Δ or LOOP Down ∇ for more than 1 second to scroll up or down through the loop numbers at high speed.

You can only change loop numbers while the 95000 is in Idle or Play modes. If the 95000 is playing back a loop and you change loop numbers, the LED Display will blink the New Loop number to indicate that you are currently playing back a different loop. The 95000 will then change to the New Loop number once the current loop has played out to its end point. If you want to change loops immediately, make sure the 95000 is idle. Then change the loop number and press PLAY. You cannot change loops while in Record or Overdub modes.

- Loop numbers can also be changed via MIDI PC and CC messages.

Erase Loops and Tracks

Erase either full loops or specific tracks by using the footswitches.

Loop Erase

In Overdub, Play or Idle Modes:

- Press and hold the TRACK and UNDO footswitches simultaneously for approximately two seconds. After the first second, all of the Track LEDs will blink rapidly to indicate that the 95000 is about to erase the currently selected loop. The Track LEDs stop blinking once the loop is erased. Then you may release the footswitches.
- Halt Loop Erase by releasing one or both footswitches before the Track LEDs cease blinking.
- You cannot undo or recover the loop audio after erasing a loop.
- Once you begin recording a New Loop on any given loop number, all of the previously recorded audio for that loop number will be overwritten and it will not be able to be retrieved.

Track Erase

In Overdub, Play or Idle Modes:

- Ensure the track you would like to erase is active, as indicated by the illuminated track button.
- Press and hold the TRACK footswitch for approximately two seconds. After the first second, both the TRACK LED and the Track Select buttons will blink rapidly. The LEDs stop blinking after the track has been erased. Then you can release the TRACK footswitch.
- If you would like to halt Track Erase, release the TRACK footswitch before the LEDs cease blinking.
- After you erase a track, you can undo the Track Erase by pressing the UNDO footswitch.
- Track Erase is disabled when you are recording a New Loop.

IN-DEPTH: OVERDUBBING TRACKS

Choose a Track to Overdub

After recording a New Loop on Track 1, the 95000 automatically advances to Track 2. If you press the PLAY footswitch to end a New Loop recording, the 95000 automatically starts overdubbing onto Track 2. Both the RECORD and PLAY LEDs light to indicate you are overdubbing.

To choose a track onto which to overdub, press the TRACK footswitch. Each press of the TRACK footswitch (preferably with the RECORD LED off) causes the buttons above the Track numbers to light consecutively. The Track Select button that is lit is the active track. You are currently (or will be) overdubbing onto the active track.

To overdub in stereo, press and hold a pair of TRACK buttons (1 & 2, 3 & 4, or 5 & 6) so that their LEDs light up. You will now be able to overdub onto Tracks 1 & 2, 3 & 4, or 5 & 6. Press the TRACK footswitch to toggle between the three track pairs. Each track fader in the stereo pairs works independently—even with Stereo Mode enabled. To return to overdubbing on single tracks, press and hold any pair of track buttons; the second TRACK button you hold down will become the active track.

Overdubbing

Begin by pressing the RECORD button on an already recorded loop. Both the RECORD and PLAY LEDs will light up immediately, and you will now be overdubbing.

If a loop is already playing back, press the RECORD button to enter Overdub mode instantly while in the middle of the loop cycle.

- Overdubbing only occurs on the track or track pair that is currently active, as indicated by the lit track LEDs.

DUB Settings (aka Feedback)

An individual track's DUB settings are displayed on the right-hand parameter of the LOOP/DUB page. To select and modify the DUB parameter:

1. Push PAGE to cycle through the 3 primary pages.
2. Push/click the VALUE knob to alternate between LOOP and DUB settings; a dot lights in the bottom right-hand corner of the display when DUB is active.
3. Select DUB and turn the VALUE knob to modify the overdub feedback amount of the active track(s). The feedback amount parameter spans a range of 0 to 10 (0% to 100%).

DUB acts like a feedback control as produced by a delay effect. When overdubbing on the 95000, the level of the previously recorded audio on the active track is multiplied by the setting of the track's DUB level. If DUB is set to 10, the previously recorded audio will remain at the same volume at which it was recorded. But if DUB is set anywhere below 10, with each pass of the loop the volume of the previously recorded audio will attenuate according to the DUB feedback setting. Using high settings such as 8 or 9, it is possible to use the 95000 as a very long delay pedal. Set DUB to 0 and all previously recorded audio will be erased.

- Use the UNDO function to undo your last overdub. If DUB was set below 10 and "old" audio was erased, restore the erased audio by pressing the UNDO footswitch.

Each Track's DUB feedback level is applied across all loops and is automatically stored in or recalled from internal memory. For example, imagine you're working in Loop 3 and you set Track 6's DUB level to a value of 7 (70%). When you switch to another loop, such as Loop 10, Track 6's DUB level will also be set to 7.

Manipulating Sounds While Overdubbing

Certain button pushes or slider movements enable you to manipulate sounds while overdubbing:

- Move the TEMPO slider and use the TAP button to achieve slowed-down or sped-up sounding instruments or vocals. Press the TAP button two or more times while in Overdub mode to immediately match the loop's BPM speed to the tempo of your TAP presses. This function works well for percussive loops, but it may result in "out of tune" loops for pitch-based loops.
 - The TAP button lights up when the TEMPO slider is set to the same tempo at which the original loop was recorded. Therefore, if you move the TEMPO slider, the TAP button will only light up when the TEMPO slider is set to its original setting. This TAP button indicator helps you to easily return to the original pitch and tempo of the loop.
 - Press the OCT button to automatically drop the pitch and tempo of the loop by exactly one octave. Use the TEMPO slider to change the speed of the loop in semitone (1/2 step) increments (COARSE mode) or in increments of 1 BPM (FINE mode). By default, the TEMPO slider is set to COARSE mode. The TEMPO slider resolution can be changed in the Secondary Mode pages.
 - Press the REVERSE button at any time (except when recording a New Loop) to reverse the playback direction of the loop. The Reverse function allows you to easily record a backwards instrument track or section.
- When using the OCT and REVERSE buttons, activating either function will act on all 6 tracks of the loop and the Mixdown track, not just the active track.

Punching-In

If the PUNCH button is activated while overdubbing, whatever was recorded previously on the active track will be erased. Punching-In is useful for situations where you want to fix a bad note or simply to erase one section or track of a loop in real time.

While playing back, push the active track's fader up so that you can properly hear the track. Enable Punch-In and press RECORD: the track will go silent. The 95000 simultaneously erases the previously recorded audio and records new material as the loop overdubs.

To perform a Punch-In:

1. Select the track you want to Punch-In.
2. Press the PUNCH button so that it lights.
3. Press the PLAY footswitch to play back the loop.
4. Once you reach the point at which you want to perform the Punch-In, press RECORD. The 95000 immediately begins erasing the "old" audio and records new audio onto the active track.
5. When the Punch-In section is finished, press RECORD again to stop recording while continuing to listen to the loop.

IN DEPTH: MIXDOWN

Mixdown Basics

The 95000 features a simple mixer that combines the 6 recorded tracks, the DRY OUTPUT tracks, and the Mixdown track. The outputs of the mixer are sent to the L and R OUTPUT jacks, Headphones and MONITOR OUT jacks. You can independently adjust the volume of any of the 6 tracks, the DRY OUTPUTs and the Mixdown track. Adjust the stereo positioning of the 6 tracks and DRY signals using the Pan knobs. **NOTE:** the MONITOR OUT jack supplies a mono mix of the Headphones stereo output.

- During mixdown, the 6 mono tracks are mixed internally inside the 95000 via Digital Signal Processing (DSP). The output of the 6 mono tracks' internal mixer is sent to the input of the Mixdown track, as well as the output jacks. The Mixdown track is a stereo track; it records both the Left and Right sides of the stereo spectrum.
- The Mixdown track records audio in real time, and any adjustments to the Track faders or Pan knobs will be recorded as audio onto the Mixdown track.
- The Mixdown track has its own fader (MIXDOWN) to control its volume level.
- You cannot record audio from the INPUT jacks directly to the Mixdown track. Only audio that has been recorded on any of the 6 mono tracks can be recorded onto the Mixdown track.
- The Mixdown track has a DUB feedback level control just like the other 6 tracks. Use the DUB setting to record onto the Mixdown track numerous times.

Performing a Mixdown

1. While the 95000 is idle, press the MIXDOWN button once. The MIXDOWN button lights up solidly to indicate that the 95000 is ready for normal mixdown.
2. Press RECORD to jump right into mixing, or press PLAY to rehearse the mixdown. If you record a mixdown that you don't like, you can always try again.
3. Pressing PLAY while Mixdown is active is exactly like pressing PLAY when any of the other tracks are active. You will not change the audio already recorded onto the 6 mono tracks; you are simply listening back to what has already been recorded.

4. Press the RECORD button when you are ready to perform a mixdown. The Mixdown track will immediately begin recording the audio from your 6 mono tracks. You do not have to start the loop from the beginning when mixing down; you can start from anywhere within the loop.
5. Once you are finished with a mixdown, press either RECORD or PLAY to stop recording.

After the Mixdown

When you complete a Mixdown track, listen back to the mix to see if you like it. If you need to fix something, try again. To start over, you can either press UNDO or set the Mixdown track's DUB level to 0 to erase the previous mix while you record a new one.

Here are some tips and tricks:

- Overdub onto the Mixdown track as many times as you like; the Mixdown track's DUB level will act like a feedback control as seen on a delay effect. This means, for example, that you could record 6 additional tracks and mix the new tracks down onto the Mixdown track. Your Mixdown track would then end up with 12 mixed tracks.
- You may want to try using external cables to bounce the Mixdown track back to one or two of the recorded tracks. If you do this, remember to keep the DRY OUTPUT sliders down to avoid introducing unwanted feedback.
- Enter Constant Tempo Mixdown mode if you want to produce flanging or pitch bend effects.

To exit Mixdown mode, press the MIXDOWN button until its LED button no longer lights, or press the TRACK footswitch to cycle through the 6 tracks.

Constant Tempo Mixdown Mode

- **NOTE:** The abbreviated term *CT Mixdown* will hereafter be used when appropriate to refer to the more bulky term *Constant Tempo Mixdown*.

During normal mixdown, the Mixdown track records at the same tempo to which the 6 mono tracks play back. All tracks are locked in at the same speed at all times, just like on a multitrack tape recorder. This speed is set by the TEMPO slider, the TAP button, or an external MIDI Clock. You can change the speed or tempo (BPM) of the 95000 while recording a normal Mixdown track, though when you play it back you will not hear any changes in pitch.

CT Mixdown mode locks the Mixdown track to the tempo or speed at which you recorded the initial loop. You can, however, change the speed of the 6 recorded tracks with the TEMPO slider to produce a Mixdown track with subtle effects like flanging, or more drastic effects like pitch bending.

When you enter CT Mixdown mode, the TEMPO slider becomes a tempo-change percentage control that ranges from -1 octave to +1 octave, with no change when the slider is set to the middle. The middle tempo always consists of the original tempo at which the loop was recorded. If you push the TEMPO slider to the top, the 6 recorded tracks will double their tempo. Push TEMPO down to the bottom, and the tempo of the 6 recorded tracks will be cut in half. When set to the center, the TAP LED lights solid to indicate that there is no change in tempo. At all other settings, the TAP LED blinks rapidly.

- The TAP button is deactivated in CT Mixdown mode.
- If you press the REVERSE button during CT Mixdown, the 6 recorded tracks will play backwards while the Mixdown track records going forward. This enables you to reverse a track (on the Mixdown track) after you had recorded it forwards.

Using Constant Tempo Mixdown Mode

While the 95000 is idle, press the MIXDOWN button until the MIXDOWN LED blinks rapidly. The 95000 must be idle to enter or exit CT Mixdown mode.

At this point, you can press either the RECORD or PLAY footswitches. Pressing RECORD puts you directly into CT Mixdown mode. Press PLAY to rehearse the mixdown.

When rehearsing the CT Mixdown, press the RECORD button at any time to overdub onto the Mixdown track.

Keep in mind that if you already have audio on the Mixdown track, you will probably want to set the Mixdown track's DUB level to 10 so that you do not lose the original audio on the Mixdown track.

- While performing a CT Mixdown, move the TEMPO slider in either direction to hear the effects of the off-speed tracks.
- In some cases of drastic TEMPO slider use, the tracks you are mixing will go out of sync with respect to their original timing.

To stop recording the CT Mixdown, press the RECORD footswitch to enter playback mode or press the PLAY footswitch to stop the 95000.

To enter or exit CT Mixdown mode, the 95000 must be idle. Press the MIXDOWN button until its LED shuts off. You may also exit CT Mixdown mode by pressing the Track footswitch.

Refer to **After the Mixdown** on the previous page for more options/ideas on what to do next.

MEMORY CARD AND USB

About the microSDHC Memory Card

- The 95000 records uncompressed 16-bit audio at a sampling rate of 44.1 kHz.
- All recorded audio is stored on removable Micro Secure Digital High Capacity (microSDHC) Memory Cards. The microSDHC card slot (labelled “microSD”) is located on the rear panel of the 95000 by the power jack.
- The 95000 only accepts cards labeled microSDHC with a storage capacity that ranges from 4GB to 32GB. We recommend you use cards with a speed class of 10 or higher, as indicated by the number inside a semicircle on the card itself. The 95000 does not accept standard-sized SD cards or cards labeled as microSD or microSDXC.

The 95000 comes supplied with a 16GB card. Its maximum loop recording time of up to 375 minutes time can be divided up however you want. For example, you could record one loop that is 375 minutes long—that’s a long song! Or record 100 loops, each 3 minutes and 45 seconds long.

The size of the card has no effect on the number of loops (100) the card can hold. To put it another way, a 32GB card cannot hold more loops than a 4GB card, but the 32GB can hold more audio and, therefore, longer loops.

- The UNDO function reduces the total recording time since older versions of each track need to be saved on the memory card.
- The 95000 will not enter Record or Playback without a proper SDHC Card inserted into its card slot.

Overview of microSDHC Memory Card Requirements, Size and Performance

- Card Type: microSDHC
- Minimum Card Size: 4GB
- Maximum Card Size: 32GB
- Card Speed: Speed Class 10 or greater
- Minimum loop recording Time: 1.5 seconds
- Approximate total loop recording time for each standard SDHC card size:
 - 4GB = 93 minutes (1 hour & 33 minutes)
 - 8GB = 187 minutes (3 hours & 7 minutes)
 - 16GB = 375 minutes (6 hours & 15 minutes)
 - 32GB = 750 minutes (12 hours & 30 minutes)

How to Format microSDHC Memory Cards

Use only microSDHC Memory Cards that are formatted with the FAT32 file system. Most cards come preformatted for FAT32. But if you do need to format a microSDHC card for the 95000, we recommend using the official SD Card Formatter tool published by the SD Association (http://www.sdcard.org/downloads/formatter_4) instead of the standard formatting utilities included with Windows and OS X operating systems. The SD Card Formatter tool is available for both Windows and Mac OS X and ensures that the card is formatted for best performance.

How to Remove the microSDHC Card

To remove the microSDHC card, push the card *into* the 95000. This action engages a spring that releases the card and pushes it partially back out of the slot. Then pull the card out the rest of the way. To exchange microSDHC cards, simply insert a new card into the open slot.

Please make sure the 95000 is idle before removing the card. Do not remove the card if the 95000 is in the process of playing, recording or overdubbing. If you do remove the card during recording or overdubbing, damage to the card’s file system may occur, and the 95000 will be unable to properly read or write to the card. If this does occur, connect the 95000 to a Windows PC with a USB cable and run the Scandisk utility on the card. For Mac users, connect the 95000 to the computer and run the Repair Disk function built into the Disk Utility app. If the card still does not work, reformat the card for FAT32 as described above.

Unfortunately, reformatting permanently erases all the loops that were on the card.

USB Port: Using the 95000 with a Computer

The 95000's USB Port allows you to move your files to and from your computer via a standard USB cable. The USB Port is located next to the microSD card slot on the rear panel of the 95000.

When you connect your 95000 to a computer through the USB connector, the computer displays the microSDHC card inside the 95000 as a "Removable Disk." You may then copy files to and from the microSDHC card. The 95000 is automatically recognized by PCs running Windows XP or later, as well as Macs running OS X.

- You can use the USB connection to upgrade the software, if necessary. Check the 95000's product page at www.ehx.com to ensure you have the latest version. Note: the software's version number "V x.y" will appear briefly during the startup procedure. If you do need to upgrade the software, instructions will be included with the software revision.

The 95000 records all audio files as WAV files which can then be read by most—if not all—modern computers. Any audio program that accepts wave files as a viable format can play or edit the 95000's audio files. Every PC and Mac can play .WAV files. The biggest plus here is that you can insert your 95000 files into your favorite software application—a sound designer's dream!

To properly unmount the USB connection between the 95000 and your computer, follow the ejection procedure appropriate to your computer operating system:

- Windows: Go to the "Safely Remove Hardware" icon down in the lower right corner of the screen. Select the USB Mass Storage Device and hit the STOP button.
- OSX: Go to the Finder and drag the SD Card icon to the Trash.

95000's microSDHC Card File System

Use a PC or Mac to import audio files made elsewhere into the 95000. You can also backup or restore loops to the microSDHC card inside the 95000.

When you look inside the microSDHC card's file system, each loop will have its own folder with labels from LOOP00 to LOOP99. Only the loop numbers that have been recorded will have a folder. For example, if you have never recorded

onto Loop 20, there will be no folder called LOOP20.

Once you double-click one of the loop folders, at least 8 files appear inside the folder. The names for the 8 files are the same in each loop folder: TEMPO.TXT; TRACK1.WAV; TRACK2.WAV; TRACK3.WAV; TRACK4.WAV; TRACK5.WAV; TRACK6.WAV; TRACKM.WAV. The loop folder may also contain files with the extensions .UND, .DAT and .TRK. When restoring a loop back into the 95000, these files are used to perform UNDO/REDO operations on tracks you previously recorded.

The .TRK files are temporary .WAV files. If you encounter a .TRK file while backing up, close the window showing the files. Play the loop you are backing up on the 95000, cycling the loop at least two times. When you look again at the files, the .TRK file will now be a .WAV file.

Backing-Up Files

1. Make sure both your computer and the 95000 are powered up.
2. Connect the 95000 to your computer with a standard USB cable.
3. Look for the removable disk in your file system.
4. Open up the Memory Card's window. You will see at least one folder: LOOP00. Each loop that you record on the 95000 will be recorded into its own LOOPxx folder.
5. Inside each LOOPxx folder are numerous files. If you plan on restoring the loop folder back to the 95000 at some point, the best way to back up any given loop is to copy the loop's entire folder to a preferred directory on your computer's hard drive. You may want to change the name of the Loop folder—once it is on your hard drive—to easily determine the contents of the folder. When backing up, it is important to save all the files in the loop folder, including the seven audio files, the TEMPO.TXT file and all UNDO files. The 95000 will only play a loop if all audio files are present, and it may not play as intended if TEMPO.TXT is not present. If hard drive space is limited, make sure to copy at least all seven .WAV files and the .TXT file. You can omit the .UND files when backing up. However, you will not be able to undo/redo overdubs from your last session when you restore the loop onto your 95000.
6. To disconnect the 95000 from the computer, follow the computer's specific ejection procedure.

Restoring Files

1. Make sure both your computer and the 95000 are powered up.
2. Connect the 95000 to your computer with a standard USB cable.
3. Look for the 95000's removable disk in your file system.
4. Locate the folder or files on your hard drive that you want to restore to the 95000. If the files are in their own folder with no other files, copy the entire folder to the root directory of the 95000's microSDHC card. If necessary, rename the folder to LOOPxx, where xx is an available loop number between 00 and 99. You do not need to restore the folder to the same loop number originally assigned to the loop.
 - When restoring files to the microSDHC card, it is important to include all seven audio files, the TEMPO.TXT file and all UNDO files. The 95000 will only play a loop if all audio files are present and it may not play as intended if TEMPO.TXT is not present. You do need to include the old UNDO/REDO files if you do not need to use them.
5. Eject the removable disk from your computer.
6. Select the loop number on the 95000.
7. Play the 95000. The audio files should be restored.

Importing Audio Files

The 95000 is capable of playing and overdubbing audio files made elsewhere, as long as you import them onto the microSDHC card using a computer and USB. Note the following important specifications you must adhere to in order for the audio import to work correctly:

- The audio files must be in .WAV format.
- The .WAV files must have 16-bit resolution and a sample rate of 44.1 kHz.
- You must have all six mono track files present, as well as the stereo Mixdown file and the TEMPO.TXT file.
- All seven audio tracks must be the exact same length.
- The TEMPO.TXT file should be copied from an established loop. In the second line, where it says TEMPO = xxx.xxxxx bpm, insert the BPM you used when creating the loops. With the 95000's TEMPO slider set to that tempo, the TEMPO LED will light up and the loops will play back at normal speed. The field that is labeled TEMPO POT should be left blank.
- You can copy the imported files to a loop folder already on the SD card (in which case you will be erasing whatever is in there at the moment), or you can create a New Loop folder by giving it any number between 00 and 99.

MIDI SYNC

Earlier in this manual, we noted that the 95000 has three Clock Sync modes. One Clock Sync mode is internal (IN). The other two modes are external: XT (Normal External MIDI Clock sync) and BX (Beat Sync External Clock mode).

Each press of the EXT. CLOCK button advances through the three clock modes:

1. IN: EXT. CLOCK button off
2. XT: EXT. CLOCK button lit solid
3. BX: EXT. CLOCK blinks rapidly

IN (Internal Clock Sync Mode)

The 95000 generates MIDI Clock based on its internal tempo settings and sends MIDI Clock, Start and Stop messages to the MIDI OUT connector. The External Clock is disabled and MIDI IN messages are ignored.

When the 95000 is set to its internal clock, it outputs MIDI Clock sync at all times at the current tempo setting. In addition to MIDI Clock, the 95000 also generates MIDI Stop and Start commands each time a loop is stopped or started.

Upon pressing PLAY or RECORD to start loop playback, the 95000 transmits a MIDI Start command. The 95000 also sends out a MIDI Start command when you press the NEW LOOP button to enter Record-Ready mode.

A MIDI Stop command is sent out when you stop a loop to put the 95000 into Idle mode. So, if the 95000 is playing a loop and you press either PLAY or RECORD to stop the loop, it sends out a MIDI Stop command.

When in Quantize mode, as soon as you press the RECORD button, the 95000 sends out a MIDI message to reset the MIDI slave device to restart its playback at beat 1.

XT (Normal External Clock Mode)

When set to XT mode, the 95000 responds not only to MIDI Clock but also to MIDI Start, Stop and SPP messages.

If your MIDI master device transmits MIDI Start and Stop commands when you begin or end playback, the 95000 responds to these commands by beginning or stopping loop playback. Press PLAY on an external MIDI

device such as a drum machine: the 95000 begins playing its loop. Press STOP on the external MIDI device: the 95000 stops.

When the 95000 is in Record-Ready mode, press the RECORD button and the RECORD LED will begin to blink rapidly. Once the 95000 receives a MIDI Start command, it begins recording the New Loop. If you are in Record-Ready mode, press the NEW LOOP button (but not RECORD). When the 95000 receives a MIDI Start command, it plays the loop it has stored in memory. If the current loop number is empty, the 95000 automatically enters Record-Ready mode.

The 95000 will also respond to SPP messages. Advance the external device (i.e., a sequencer or drum machine) to any measure, and the 95000—whether idle or playing a loop—will jump to the measure specified by the MIDI master device. If the specified measure is outside the loop's length, the 95000 will wrap the loop around to the correct position.

For example, set the 95000 to a 4-bar loop. Move a sequencer to the beginning of measure 6 and press PLAY. The 95000 will start playing from the beginning of its 2nd bar. With the LED display set to show BARS/BEATS, the 95000 will display the current loop location as you change it with MIDI.

- The 95000 works best with MIDI master devices that send out a continuous MIDI Clock signal. However, some devices only send MIDI clock signals when you start playback. With these type of devices, if the MIDI master tempo has been changed since it last sent out a MIDI Clock signal, the 95000 will need to play through 1 to 3 bars of its loop to fully adjust to the new tempo. During this time, you may hear the 95000 dramatically adjust the speed of the loop.

BX (Beat Sync External Clock Mode)

BX mode is similar to XT mode, except in BX mode the 95000 ignores MIDI Start commands. As a result, playback can start on the MIDI master device without the 95000 beginning playback immediately. When the MIDI master is started, the 95000 follows the master's MIDI

clock so that the 95000 is synchronized to the master's location. When you press PLAY, the 95000 starts playback at the beginning of the loop in sync with the beat generated by the master MIDI device.

- The 95000 always starts playback at the beginning of its loop in Beat Sync External Clock mode.
 - The 95000 always waits for the next MIDI master beat to start playback after you press PLAY or RECORD. This behavior insures that the 95000 remains in sync with the master MIDI Clock.
 - If you want the 95000 to sync up with beat 1 of the MIDI master device, press PLAY on the 95000 just before the MIDI master device's beat 1.
- **NOTE:** While in either XT or BX mode, the 95000 "waits" for the MIDI Clock signal. If no MIDI Clock signal is available when you press PLAY, the PLAY LED blinks rapidly to indicate the 95000 is unable to establish sync with the MIDI master device. The RECORD LED blinks rapidly if you try to overdub or record a New Loop with no MIDI Clock present.

TUTORIAL: the 95000 as MIDI Clock Slave and MIDI Clock Master

When the 95000 is used with MIDI Clock—either as a slave or master, enable Quantize mode to insure that loop lengths are exact bar lengths. If you do not use Quantize mode, a loop's length will be slightly longer or shorter than bar lengths. This mismatch causes the loops to drift in relation to the MIDI clock master or slave, even though the tempos are actually locked.

95000 as MIDI Clock Slave

If you are using the 95000 as a MIDI Clock slave and want to produce loops of a set number of bars, record the initial loop (or New Loop) with Quantize set to ON as follows:

1. Start with an empty loop number.
2. Enable Ext. Clock mode by pressing the EXT. CLOCK button so that it is lit solid or blinking.
3. Press the QUANTIZE button. The QUANTIZE button lights when Quantize mode is enabled.
4. Press the NEW LOOP button. The RECORD LED should blink steadily.

5. Press the RECORD footswitch. Now the Record LED blinks rapidly. The 95000 is waiting for a MIDI Clock signal and the Start command from the MIDI master. Once the Start command is received, the 95000 immediately begins Count-In or (if Count-In is disabled) recording.
 6. Press PLAY on the MIDI clock master. The 95000 will immediately start the 1-bar Count-In. You may disable the Count-In or set it to any length between 1-8 bars. We recommend using at least a 2-bar Count-In when recording with MIDI Clock. This approach ensures that the MIDI Clock master and slave sync with each other by the time actual loop recording begins.
 7. In BX mode, the MIDI master can be playing back when you press NEW LOOP or RECORD.
 - Make sure that BX mode is selected at the time you start playback on the MIDI master.
 - After pressing the RECORD footswitch, the 95000 will begin recording on the next Beat 1 that it receives from the MIDI master, even if Count-In is disabled.
 - If Count-In is enabled, the 95000 will count off the specified number of bars prior to recording.
 8. Press the PLAY or RECORD footswitch during the 3rd or 4th beat of the last bar. The 95000 will set the loop length automatically at the end of the bar.
 9. In Quantize mode, the 95000 creates loop lengths to the nearest bar. Each bar may be 1 to 8 beats in length. The default length is 4 beats per bar.
- **EXAMPLE:** Create a 4-bar loop in which each bar is 4 beats long. Begin recording a New Loop with Quantize enabled. During recording, press the PLAY footswitch to set the loop length either after the 3rd beat of the 4th bar or before the 2nd beat of the 5th bar. The 95000 will either extend or truncate the loop length to be exactly 4 bars long. At the end of the 4th bar, the 95000 will stop recording and immediately begin playing/overdubbing the loop you just recorded. To play the loop without overdubbing, press the RECORD footswitch instead of PLAY to end the loop.

- **NOTE:** In order for the 95000 to start recording a loop, one of the External Clock modes needs to be selected at the time you start playback on the MIDI Clock master. The 95000 needs to receive a MIDI Start command—followed by subsequent MIDI Clock messages—for it to “know” where it is located within MIDI Clock bars.

PRO TIP: If the loop length (in bars) is known prior to recording the loops, create a blank loop before you start recording with MIDI Clock. For example, if you create a 2-bar loop with Quantize set to ON, then that loop will always be exactly 2-bars long. This length is always established regardless of whether the tempo is set internally by the 95000 or it is set to EXT. CLOCK and is receiving MIDI Clock sync.

You can create the 2-bar loop without any MIDI being sent to the 95000. Afterward, you can turn on an External Clock mode and supply MIDI Clock to the 95000. The 95000 will record/play at the master’s tempo and the loop will always be 2 bars. You could even make multiple loops on the microSDHC card with different loop lengths. Loop 0 could be a 2-bar loop, Loop 1 a 4-bar loop, and so on. If you don’t want (or need) the audio that was recorded the last time you started with a blank loop, just erase each track individually.

95000 as MIDI Clock Master

When EXT. CLOCK is disabled, the MIDI Clock tempo output by the 95000 has nothing to do with loop length and only relates to the current tempo setting of the 95000, whether set by the TEMPO slider or the TAP button. To use the 95000 as the MIDI Clock master:

1. Start with an empty loop number.
2. Press the EXT. CLOCK button so that its light is off. External Clock mode is now disabled and Internal Clock Sync mode is enabled.
3. Press the QUANTIZE button so that it is lit. Quantize mode is now enabled.
4. Press the RECORD footswitch. The 95000 immediately sends out a MIDI Start message to the MIDI Clock slave and the slave begins playing. The 95000 starts its Count-In. If Count-In is disabled, the 95000 begins recording immediately. We recommend setting at least a 2-bar Count-In when syncing MIDI to allow MIDI Clock to settle into the correct tempo before actual recording begins.
5. After the Count-In, the 95000 begins recording; the MIDI Clock should be playing along.
6. To set the loop length, press the PLAY or RECORD footswitch during the 3rd or 4th beat of the last bar of the loop. The 95000 will set the loop length automatically at the end of the bar.

MIDI CONTROLLER AND PROGRAM MESSAGES

Overview

Use MIDI to engage remote and automated control over nearly all the 95000's buttons, sliders and rotary controls. The exceptions are the L and R INPUT LEVEL knobs and the HEADPHONES LVL knob; since these controls are fully analog they cannot be controlled via MIDI. The 95000 responds to Control Change (CC) and Program Change (PC) messages at all times. The 95000 does not send PC and CC messages, it only receives these messages.

Set the MIDI Channel

The 95000 only responds to MIDI Control Change (CC) and Program Change (PC) messages if both the MIDI master and slave devices are set to the same channel. To set the MIDI channel on the 95000:

1. Press the PAGE button until the MIDI CH/SYNC LED under the display is lit.
2. The left two digits on the display represent the MIDI channel setting. Ensure the decimal point immediately to the right of the MIDI Channel setting is lit. If it is not, press and release the VALUE knob once.
3. Turn the VALUE knob to change the MIDI Channel.
4. You may set the MIDI channel to any channel between 1 and 16 or you may set it to OM, which stands for OMNI. OMNI mode is the setting above 16. When OMNI is selected the 95000 responds to all MIDI channels.

MIDI Control Change (CC) Messages

MIDI CC messages are primarily used to vary continuous controls such as track volume faders, pan knobs and the TEMPO slider. They may also be used for button presses, controlling the VALUE knob (which is not attached to any PC messages), and selecting Loop numbers. The tables on the next page list all the functions controlled by MIDI CC, as well as the CC numbers they are associated with.

- MIDI CC3 allows for the “press” of all buttons on the 95000, including control over the VALUE knob's up, down and pushbutton abilities. Use the CC3 Data Field Value, as shown on the table on the next page, to send the exact button press command.

- Use the Data Range of MIDI CC115 to directly select loop numbers. The range of CC numbers from 0 to 99 directly matches the loop numbers of the 95000.

MIDI Program Change (PC) Messages

Employ MIDI PC messages to directly select any of the 100 loops on the microSDHC card, or to trigger a button press of any button on the 95000's top panel except for the VALUE knob's push/click to toggle function. Additionally, MIDI PC messages can be used to individually mute or unmute each of the 6 mono tracks and the Mixdown track. See the **MIDI Program Change (PC) Messages** table on p.37 for reference.

MIDI Thru

When set to either EXT. CLOCK mode, the 95000 relays all received MIDI messages to the MIDI OUT connector. In other words, the MIDI OUT connector also acts as a MIDI THRU connector.

NOTE: When set to Internal Clock Sync mode, the 95000 does not relay MIDI messages.

Change Loop Numbers with MIDI

You can use an external MIDI device to change and load loops with PC or CC messages.

MIDI CC Tables

The table on the left lists each 95000 Control Change number (CC#), the data range used by each CC#, and the parameter assigned to each CC#. The table on the right lists all of the button presses and their associated data values available through CC3.

MIDI Control Change Messages

CC#	Data Range	Parameter
3	0 to 127	Button Presses
7	0 to 127	MASTER LVL knob
9	0 to 127	CLIX LVL knob
14	0 to 127	DRY OUTPUT L Volume Fader
15	0 to 127	DRY OUTPUT R Volume Fader
20	0 to 127	Track 1 Volume Fader
21	0 to 127	Track 2 Volume Fader
22	0 to 127	Track 3 Volume Fader
23	0 to 127	Track 4 Volume Fader
24	0 to 127	Track 5 Volume Fader
25	0 to 127	Track 6 Volume Fader
26	0 to 127	MIXDOWN Volume Fader
27	0 to 127	TEMPO Slider
28	0 to 127	EXPRESSION PEDAL
29	0 to 127	DRY OUTPUT L Pan knob
30	0 to 127	DRY OUTPUT R Pan knob
85	0 to 127	Track 1 Pan Knob
86	0 to 127	Track 2 Pan Knob
87	0 to 127	Track 3 Pan Knob
88	0 to 127	Track 4 Pan Knob
89	0 to 127	Track 5 Pan Knob
90	0 to 127	Track 6 Pan Knob
102	0 to 127	Track 1 Overdub setting
103	0 to 127	Track 2 Overdub setting
104	0 to 127	Track 3 Overdub setting
105	0 to 127	Track 4 Overdub setting
106	0 to 127	Track 5 Overdub setting
107	0 to 127	Track 6 Overdub setting
108	0 to 127	MIXDOWN Overdub setting
109	0 to 8	Count-In Secondary Page
110	0 to 1	TEMPO Slider Resolution Secondary Mode page setting
111	0 to 2	Clix Mode Secondary Mode page
112	0 to 99	Fade-Out Secondary Mode page
113	127	Loop Down
114	127	Loop Up
115	0 to 99	Loop Direct Select
116	1 to 8	Number of beats per bar

MIDI CC3

CC3 Data Field Value	Button Press
1	VALUE Knob Press
2	VALUE Knob Down
3	VALUE Knob Up
100	TRACK FSW Press
101	UNDO FSW Press
102	RECORD FSW Press
103	PLAY/STOP FSW Press
104	LOOP DOWN FSW Press
105	LOOP UP FSW Press
106	NEW LOOP Button Press
107	REVERSE Button Press
108	OCT Button Press
109	TAP Button Press
110	Track 1 Button Press
111	Track 2 Button Press
112	Track 3 Button Press
113	Track 4 Button Press
114	Track 5 Button Press
115	Track 6 Button Press
116	MIXDOWN Button Press
117	PUNCH Button Press
118	QUANTIZE Button Press
119	PAGE Button Press
120	Mute/Unmute Track 1
121	Mute/Unmute Track 2
122	Mute/Unmute Track 3
123	Mute/Unmute Track 4
124	Mute/Unmute Track 5
125	Mute/Unmute Track 6
126	Mute/Unmute MIXDOWN
127	EXT. CLOCK Button Press

Please Note:

- There must be at least 300mS between each button push message.
- Moving a fader or knob after receiving a CC message will overwrite the last CC message with the last fader or knob movement.

MIDI Program Change (PC) Messages

The 95000 responds to PC messages to allow the direct selection of loops, initiate button pushes and mute/unmute all tracks.

PC #	Function
0	Select Loop 00
1	Select Loop 01
...	
99	Select Loop 99
100	TRACK FSW Press
101	UNDO FSW Press
102	RECORD FSW Press
103	PLAY/STOP FSW Press
104	LOOP DOWN FSW Press
105	LOOP UP FSW Press
106	NEW LOOP Button Press
107	REVERSE Button Press
108	OCT Button Press
109	TAP Button Press
110	TRACK 1 Button Press
111	TRACK 2 Button Press
112	TRACK 3 Button Press
113	TRACK 4 Button Press
114	TRACK 5 Button Press
115	TRACK 6 Button Press
116	MIXDOWN Button Press
117	PUNCH Button Press
118	QUANTIZE Button Press
119	PAGE Button Press
120	Mute/Unmute Track 1 *
121	Mute/Unmute Track 2 *
122	Mute/Unmute Track 3 *
123	Mute/Unmute Track 4 *
124	Mute/Unmute Track 5 *
125	Mute/Unmute Track 6 *
126	Mute/Unmute MIXDOWN *
127	EXT. CLOCK Button Press

- * *The single channel mute/unmute action works as follows: if the channel's level is greater than zero when the command is received, the channel will be muted. If the channel's level is zero when the command is received, the level will be set either to that of 95000's current track fader position or to that of the last CC message (20-26), depending on which was the last received.*

SIGNAL PATH DIAGRAM

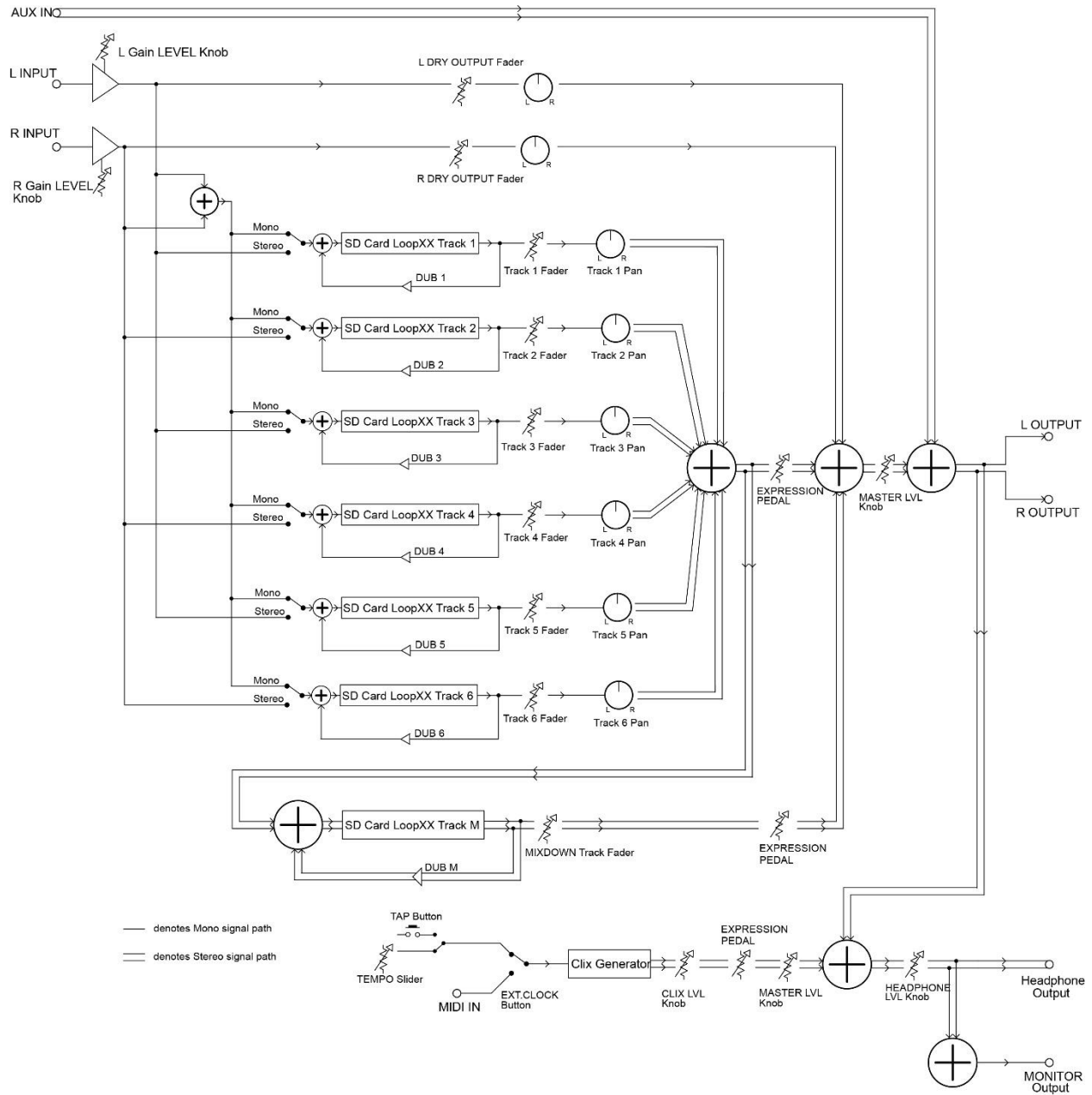

FACTORY DRUM LOOPS

The microSDHC card supplied with your 95000 comes equipped with 20 factory drums loops to help get you started. The factory drums are located on the Mixdown track of Loops 1-20. If you erase any of these loops, the factory drums for that particular loop number will also be erased. If you would like to restore the factory drums for any or all of the loops, they are available for download on the 95000's product page at www.ehx.com.

Loop Number	Description	BPM
1	4/4 Stick Metronome	100
2	4/4 Kick Drum	100
3	4/4 Electro Kick	100
4	Funky Beat	100
5	Rock Beat	100
6	Heavy Drums	120
7	Rock Beat 2	100
8	Tom Rock Beat	100
9	Funky Beat 2	110
10	Boots & Cats	100
11	90s Hip Hop	100
12	Slow Jam	72
13	Funk 3	80
14	DRM32	108
15	CR78	100
16	Jazz Drums	140
17	Country	112
18	Bossa Nova	120
19	3/4 Stick Metronome	120
20	6/8 Rhythm	200

Loops 5, 13 and 16 courtesy of studio drummer Hans Eijkenaar, <http://www.drumloopshd.com>.

WARRANTY

Please register online at <http://www.ehx.com/product-registration> or complete and return the enclosed warranty card within 10 days of purchase. Electro-Harmonix will repair or replace, at its discretion, a product that fails to operate due to defects in materials or workmanship for a period of one year from date of purchase. This applies only to original purchasers who have bought their product from an authorized Electro-Harmonix retailer. Repaired or replaced units will then be warranted for the unexpired portion of the original warranty term.

If you should need to return your unit for service within the warranty period, please contact the appropriate office listed below. Customers outside the regions listed below, please contact EHX Customer Service for information on warranty repairs at info@ehx.com or +1-718-937-8300. USA and Canadian customers: please obtain a Return Authorization Number (RA#) from EHX Customer Service before returning your product. Include—with your returned unit—a written description of the problem as well as your name, address, telephone number, e-mail address, RA# and a copy of your receipt clearly showing the purchase date.

United States & Canada

EHX CUSTOMER SERVICE
ELECTRO-HARMONIX
c/o NEW SENSOR CORP.
55-01 2ND STREET
LONG ISLAND CITY, NY 11101
Tel: 718-937-8300
Email: info@ehx.com

Europe

JOHN WILLIAMS
ELECTRO-HARMONIX UK
13 CWMDONKIN TERRACE
SWANSEA SA2 0RQ
UNITED KINGDOM
Tel: +44 179 247 3258
Email: electroharmonixuk@virginmedia.com

FCC COMPLIANCE

Note: This equipment has been tested and found to comply with the limits for a Class B digital device, pursuant to part 15 of the FCC Rules. These limits are designed to provide reasonable protection against harmful interference in a residential installation. This equipment generates, uses and can radiate radio frequency energy and, if not installed and used in accordance with the instructions, may cause harmful interference to radio communications. However, there is no guarantee that interference will not occur in a particular installation. If this equipment does cause harmful interference to radio or television reception, which can be determined by turning the equipment off and on, the user is encouraged to try to correct the interference by one or more of the following measures:

- Reorient or relocate the receiving antenna.
- Increase the separation between the equipment and receiver.
- Connect the equipment into an outlet on a circuit different from that to which the receiver is connected.
- Consult the dealer or an experienced radio/TV technician for help.

Modifications not expressly approved by the manufacturer could void the user's authority to operate the equipment under FCC rules.



electro-harmonix
55-01 2nd Street, Long Island City, NY 11101
www.ehx.com