



MIDI Kit for Korg Monotribe

This board enables MIDI functionalities in Korg Monotribe. Based in Gameboy Genius documentation, to take advantage of hidden features in this machine.

Three versions are available:

- A - External. Solderless and no drilling.
- B - Internal. Solderless. No drilling also possible but recommended.
- C - Do it yourself! PCB, componenets and assembly instructions provided.

Features at a glance:

- Note ON/OFF, LFO parameters and EG control in synth part
- Sequencing via MIDI for drum section.
- MIDI Sync IN and OUT.
- Sends MIDI OUT for synth part parameters and drums separately.
- Works as MIDI clock to Sync and Sync to MIDI clock converter.

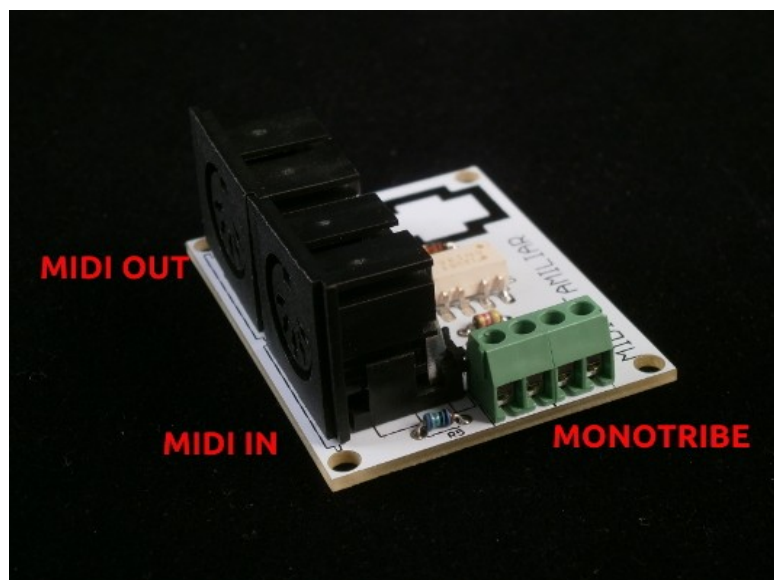

A - EXTERNAL VERSION

WARNING: Opening Monotribe voids it's warranty. We do not take responsibility of any harm done to de device due to unsuitable handling.

1 – Remove rubber feet and take the four screws out.



2 – Take out the connector between mAin board and power case.

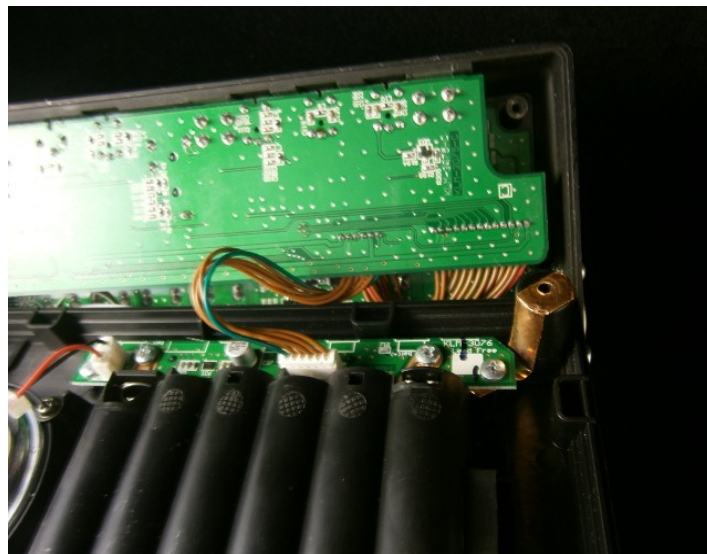

4.2 – Through battery compartment.

Pass wires through battery compartment hole. This will avoid it to close anymore.

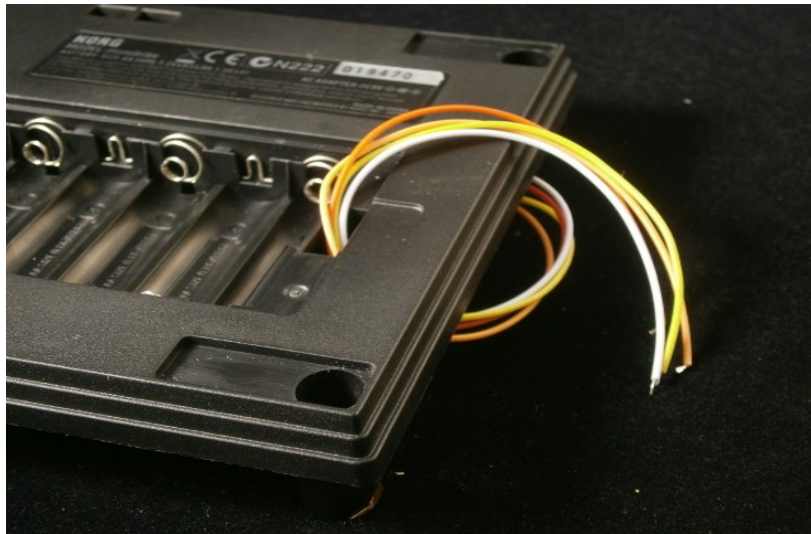

5 – Close monotribe, reversing procedure.

6 – Connect wires to the Board following this order:

White – Red – Yellow - Orange

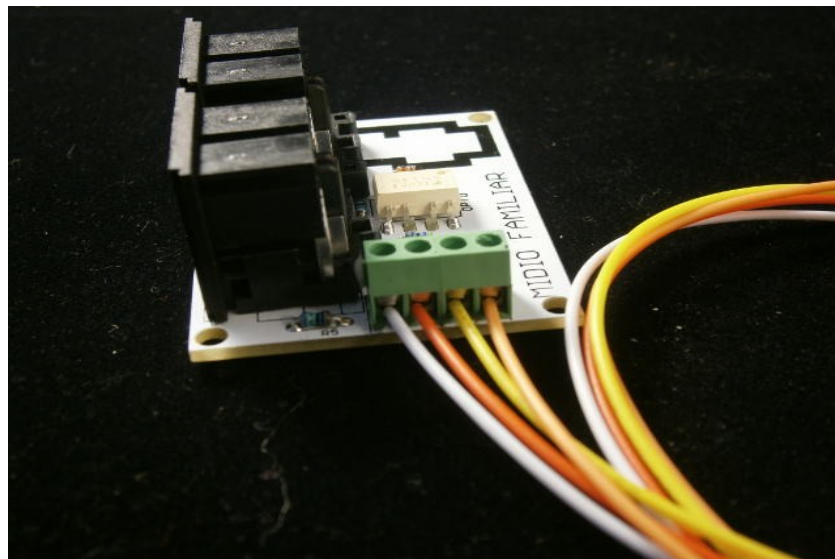

B – INTERNAL VERSION

1 – Follow steps 1, 2 y 3 from external kit section.

2 – DIN5 connectors are pre-wired. MIDI IN one has two wires, MIDI OUT three. This is DIN5 pinout.

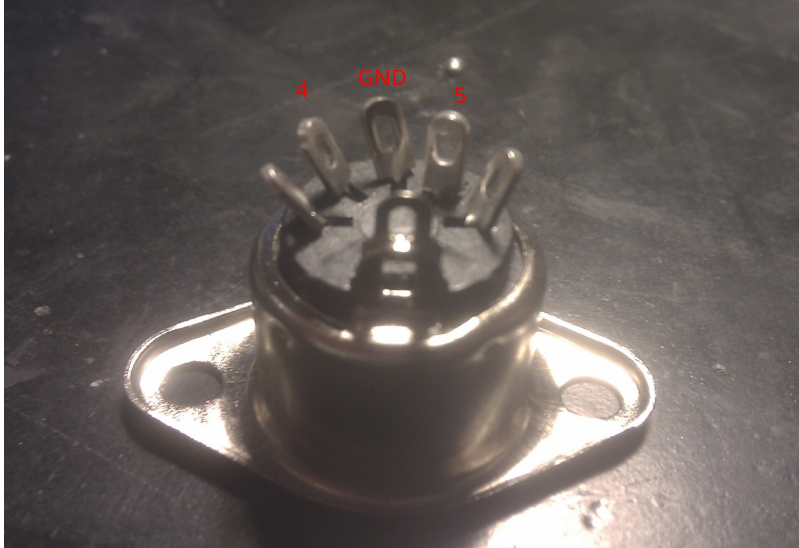

3 – Board wiring Diagram:

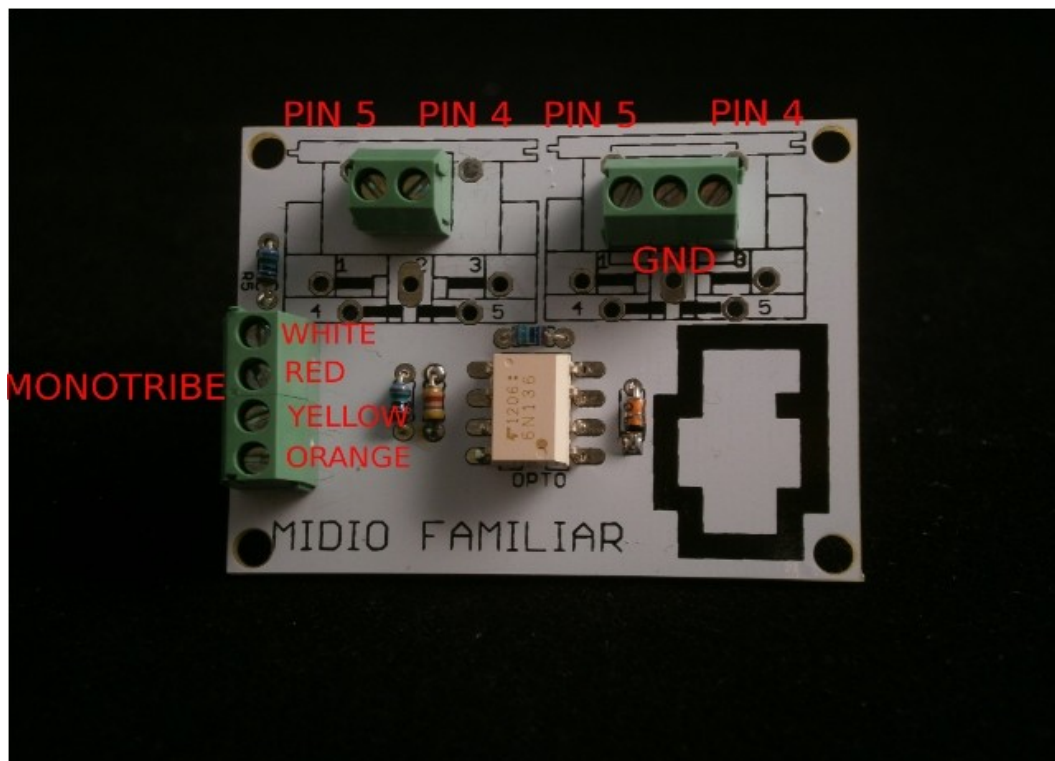

We recommend to drill the case to accommodate DIN5 connectors, although you might follow step 4 in internal Kit version to avoid drilling.

C - Do It Yourself!

WARNING: Soldering to Monotribe's board could harm the unit if not done carefully. Advanced skills recommended. We do not take responsibility for incorrect handling beyond these instructions.

Part list and location in board:

R2,R3,R5	150 ohm (Might be 180 ohm , depending batch)
R1	4K7
D1	1N4148 (Mind the black stripe in the diode)
OPTO	6N136 (Dot in IC marks orientation)

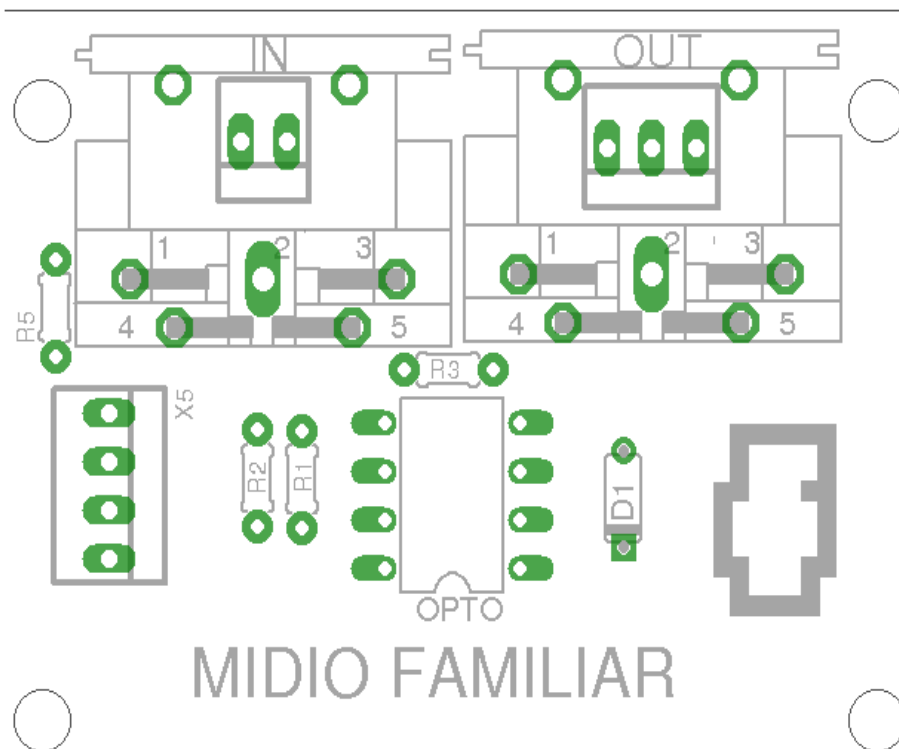

Monotribe Connector

Solder cables to X5 pads in following order: **WHITE, RED, YELLOW, ORANGE**

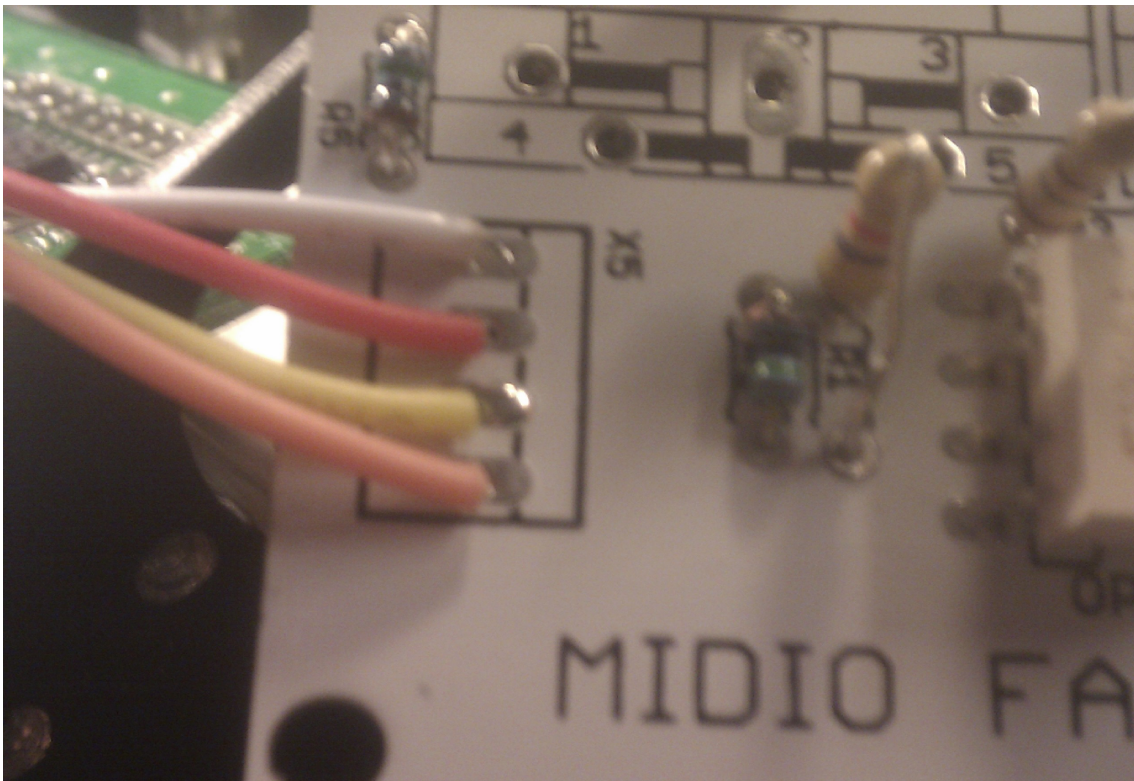

Connect cables to Serial port following this pinout and above color schema.

- 1 – Orange (GND)
- 2 – Yellow (VCC)
- 3 – White (MIDI OUT)
- 4 – Red (MIDI IN)

Orientative description. Better to solder under the board.



DIN5 MIDI Connectors

MIDI IN y MIDI OUIT are written in the board as IN and OUT. Solder cables minding pinout.

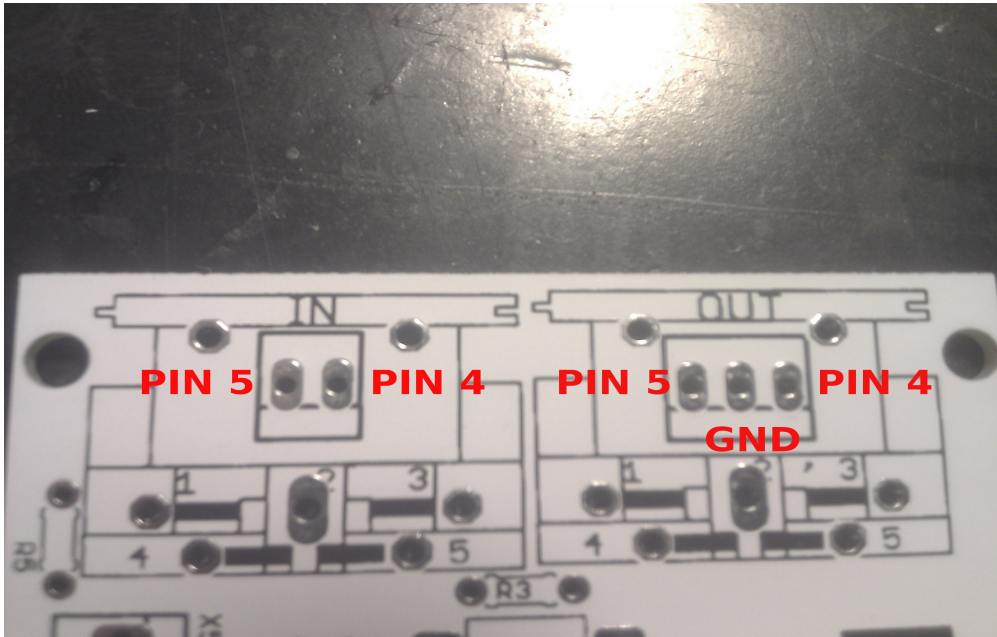

MIDI Features

WARNING: MIDI feature is unsupported by Korg and has some limitations.

Synchronisation and sequencer.

Receives and sends MIDI clock and start/stop. These can be combined with Monotribe's Sync IN/OUT to act as a MIDI clock to sync or sync to MIDI clock converter.

Records notes from MIDI in into internal sequencer memory. Synth section works as an arpeggiator, storing pitch information in sequencer's steps, to control external devices.

Synth steps will be sent via MIDI even if step is disabled. You'll need to use the ribbon + "Active Step" to control volume in each step.

External devices must accept Volume Controller - CC 7 (applicable only in Firmware v2)

KNOWN ISSUES: After using MIDI as clock source, if sync IN wants to be used, Monotribe need to be reseted. This is a design Limitation.

Drum Section

Drum section is triggered via MIDI channel 10.

Name	N° Note	Name	Drum Name
BD	36	C1	Bass drum 1
SN	40	E1	Snare dum 2/Electric snare
HH	42	F#1	Closed hi-hat

Both MIDI IN and OUT uses this channel and same notes.

Synth section.

NoteON/OFF via channel MIDI 1

KNOWN ISSUES: A note could be stuck if a note OFF message is not received. Some devices and software can send several differnet note ON but not a NOTE OFF for every note sent.

Clicking sound is Monotribe's design limitation and cannot be avoided.

Control change messages (CC)

Name	CC	Value	Parameter
LFO rate	16	–	Control general 1
LFO int.	1	–	Modulación
EG shape	80	32=decay 64=sustain 96=attack	Control general 5
LFO target	81	32=VCO 64=VCO+VCF 96=VCF	Control general 6
LFO mode	82	32=Fast 64=Slow 96=1shot	Control general 7
LFO wave	83	32=Saw 64=Triangle 96=Square	Control general 8
VCA Level*	7 11	-	Volume or Expression
MIDI Velocity to VCA LEVEL*			

* Only available in Firmware version 2.0

Acknowledgments, Credits, info and Kudos!

No rights reserved. This board wouldn't have been possible without the information posted by Gameboy Genius and Muffwiggler forum members.

All Kudos for them.

If you want to make this board from scratch, download eagle file here:

<http://famfest.info/eagle/MIDITRIBE.ZIP>

All needed information:

<http://blog.gg8.se/wordpress/2011/08/14/monotribe-midi-and-me/>

<http://www.muffwiggler.com/forum/viewtopic.php?t=39099>

<http://famfest.info>